

*Welcome to ProComp,
This exciting new instrument is the result of many years of effort by
our development team. Our goal was to build the most powerful,
useful and reliable instrument you have ever owned.*

*Yet it's friendly! Once you begin to play with ProComp you'll
discover that it has every feature you'll ever want, while being very
easy to use. There are no surprises while Programming or while
running a Race. We believe you'll agree that it has all the right
stuff!*

Our ProComp development team

Hardware design: Carl Laplace

Software design: Kerry Mackenroth

Software engineer: Charles Alexander

*And a special thanks to the following riders for
their contributions during product development:*

Alan Gravitt

Randy Hawkins

George Hoffer

Dennis Larrat

Steve Pierce

Alan Randt

Malcolm Smith

George Waller

Features

Thumb Switch

- All of the following features are right at the tip of your thumb. As a back up, the buttons on the instrument head can also be used to access most of these features.

Race Data

- Enter Speed changes, Resets, Free time or Known controls in the order in which they occur, straight off your race sheet.
- Multiple loops back to 000.0 can be entered into your Program.
- Holds up to 42 lines of Race Data.

Programming

- Checks for errors while you are Programming.
- Back step to view previous lines of data.
- Get Out at any point, even with a partial Program entered.

checking your Program

- Resume entering the rest of a partial Program.
- You can manually bump thru your Program.
- Or you can setup automatic, hands-off scanning.
- Stop scanning at any point.
- Back step to view previous lines of data from any point.
- Change any incorrect number while you are checking.
- Add a single line to your Program.
- Delete a single line, or the entire Program.
- Get Out from any point.

Ahead

The number of minutes before your row is due to leave that you wish to start your instrument.

- Set from 0 to 99 minutes.
- Stays set to your preference from Race to Race.

Running a Race

Switch between 3 primary readouts:

- Late/Early - Minutes & seconds from perfect schedule.
- Seconds - Readout of real clock seconds.
- Mileage - Your current instrument Mileage.

Features

Advanced Race features

- Peek at the ground distance to the next Possible.
- While in a check you can Mark the check's location. ProComp then adds the 3 mile free zone for it's next Possible calcs.
- Peek at the Speed average of the section you are in.
- Peek at the wheel size your instrument is currently using.

Enhanced AutoCal

- Automatically re-calibrates your wheel size to match the bike used to lay out the course.

InFo

Lookup InFo from your last use:

- AutoCal Wheel Size at the finish of the last Race.
- Top speed you reached.
- Trip distance - The ground distance of the last use.
- Odo distance - The cummulative Mileage on your instrument.

straight odo

Can be run as a straight odo. Switch between 3 readouts:

- Mileage.
- Current speed.
- Top speed.

Count

This feature is useful for the setup of your magnet & sensor.

- Counts how many times your sensor has closed.
- A tick mark on the readout turns on while the sensor is closed.

Calibrate

Your wheel size can be set to:

- .1 inch to 99.9 inches for running in Miles.
- 1 to 999 centimeters for running in kilometers.

Pro3 Mode

Switch to Pro3 Mode, with 2 readouts:

- Your "should be" distance for that instant in the Race.
- Clock of minutes & seconds from the start of the Race.

Misc

- Will handle Races up to 299.99 Miles/Kilometers or up to 18 hours long.
- Battery life is approximately 150 hours of ON time.

Contents

Intro	How to use this manual	1
	Switch Graphics.....	2
	Messages.....	4
ChEc	Moving thru ChEc.....	8
	Ready	8
	Flashing Readout	9
	Steady Readout	10
	Out of ChEc	11
	ChEc Summary.....	12
	Programming	Moving into Programming.....
Ahead		13
Changing any number.....		14
Final View		14
Program Map.....		15
Free Time.....		15
Error checking.....		16
Programming Race Data.....		17
Checking Race Data.....		19
Main Menu with a " d "		19
Automatic Scanning.....		20
Mileage at a fractional tenth.....		21
LEAP.....		22
Speeds above 99 MPH.....		22
Known controls (Optional).....		23
Adding a single line.....		24
Deleting a single line.....		25
FULL.....		26
Deleting an entire Race.....		27

(Continued on next page)

Contents

Running a Race

How to use ProComp in a Race.....	28
Overriding your Ahead minutes.....	30
Starting.....	31
Switching Readouts.....	32
Late/Early readout	33
Seconds readout	34
Mileage readout	35
About AutoCal™	36
Programmed Wheel Size.....	36
Manual Adjust Mode.....	37
AutoCal™ On/Off.....	37
Peek at Wheel Size.....	38
Races with no Resets.....	38
Next Possible.....	39
Marking a control.....	41
Current Speed & Top Speed.....	43
Pro3 mode.....	44

Running as a Straight Odo

Straight Odometer/Speedometer.....	45
Clearing Top Speed.....	45
Count.....	46
Sensor closed	46

Misc.

Calibrate wheel size.....	47
Switching between English/Metric ...	48
Installing Batteries.....	49
Settings you lose	49
More Info.....	50
Races with multiple loops	50
Cautions.....	51
Sensor Troubleshooting.....	52
Instrument Troubleshooting.....	53
Spare Parts.....	54
Limited Warranty.....	55

How to use this manual

Don't let the size of this manual fool you. Since ProComp is a powerful instrument, with every feature you'll ever need, it needs many pages to communicate all of it's features. However, it's designed so that you can run a Race & use only a small number of basic functions. The more advanced functions will always be there, waiting in the background for when you wish to use them.

Naturally, many of you will want to start pressing buttons right away to see what happens. While that won't hurt anything, it'll take you a long time to learn how to use all of the features. The preferred way is to walk thru each page of the manual, trying each example with your ProComp in hand.

Enjoy!

install the batteries

Go to the page covering battery installation & install the batteries. Be sure to short across the contacts as shown. This assures a clean powerup of your instrument. After shorting the batteries, hold both buttons on the instrument head to shut it off. Then bump the bottom button to turn ProComp back on.

Hookup the Thumb Switch

Next we'll connect the Thumb Switch. First connect black to black, then connect 1 red wire from each side. Bump the top button on the Thumb Switch. If the readout increments by .01 you have the correct match. If the readout blinks while bumping the top button, swap wires & connect the remaining red pair.

read Intro, ChEc & Programming

Finish reading this Intro section, then review the ChEc section. Here's where you'll actually begin pressing buttons & looking at features. Next is Programming, where you'll enter a sample Race into memory.

run a mock Race

With ProComp in your hand, you'll run a sample Race. Don't be afraid of pressing buttons or trying weird things. That's a good way of learning how difficult it is to screw up while in a Race.

Reference Maps

As you step thru each page, you may want to occasionally jump to the reference maps at the back of the manual. These are very useful for an overview of the logic flow.

Switch Graphics

The 3 buttons on the Thumb Switch allow you to program Race Data, and to move among ProComp's various functions. Below is a brief summary of the graphics used to depict the various Thumb Switch actions, **but don't press any buttons yet!**

Thumb Switches



BUMP BOTTOM BUTTON

This graphic depicts a quick bump of the bottom button.



SHORT HOLD BOTTOM BUTTON

A short hold takes about half a second. The readout will blink when it's time to release.



LONG HOLD BOTTOM BUTTON

A long hold takes about 3 seconds. During that time a Moving Message will be displayed.



BUMP TOP BUTTON



LONG HOLD TOP BUTTON

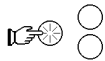

BUMP MAIN BUTTON

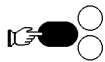

LONG HOLD MAIN BUTTON

(Continued on next page)

Switch Graphics

The 2 buttons on the instrument head generally respond the same as the top & bottom buttons of the Thumb Switch. This allows you to Program & Run the instrument even if the Thumb Switch is disabled. Below are the graphics used for the instrument head switches.

Instrument Switches



BUMP BOTTOM BUTTON

Generally the same as bumping the Bottom Thumb Switch, except the Instrument bottom is the only button which will wake up the instrument from the OFF mode.



SHORT HOLD BOTTOM BUTTON

Always the same as short hold of the Bottom Thumb Switch.



LONG HOLD BOTTOM BUTTON

Always the same as long hold of the Bottom Thumb Switch.



BUMP TOP BUTTON

Always the same as bumping the Top Thumb Switch.



LONG HOLD TOP BUTTON

Always the same as long hold of the Top Thumb Switch.



BUMP BOTH BUTTONS

Always the same as bumping the Main Thumb Switch.



LONG HOLD BOTH BUTTONS

Generally the same as long holding the Main Thumb Switch, with several exceptions noted later in the manual.

Messages

Your instrument will display messages at various times which will help you to move around it's many functions. There are 4 types of messages: Moving, Fixed, Error and Menu.

Moving Messages

Moving Messages sometimes appear while you are LONG HOLDING a button. These messages tell you where you are going & how long it will take to get there. If you release before the display blinks you will snap back to your starting point.

If the message tells where you want to go, continue to HOLD. If it's not what you want, simply release!



ChEc

Moves you into **ChEc**, where you can enter or delete a Program, change your Wheel Size, or lookup information from your last Race.

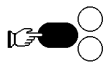

Out

Moves you **Out** of **ChEc** and back to Ready.



d A

Moves you to the **d A** Menu, where you can **delete** or **Add** single race entries.



Cm

Switching to a wheel size in centimeters.



Inch

Switching to a wheel size in **Inches**.



Cl

Clears **top Speed**.

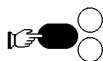

Shut OFF

Shuts the instrument **OFF**.

(Continued on next page)

Messages

Fixed Messages

Fixed Messages are displayed to describe the meaning of a value coming up, such as **top SPEd**.

Inch

Your programmed wheel size is in Inches.

CEt

Your programmed wheel size is in Centimeters.

Auto

CAL

AutoCal wheel size from last Race.

top

SPEd

Top Speed from the last use

tr IP

d .5t

Trip Distance, ground distance from last use.

0da

d .5t

The cummulative distance on the instrument.

to

You are between the 1st & 2nd half of a Reset.

End

The **End** of the Race Data you have entered.

FULL

All 42 lines available for Race Data are **FULL**.

Error Message

An Error Message may flash while you are entering a program for a race.

Err

You have entered a Speed change at a non-possible, or a Mileage point which is less than the previous Mileage.

(Continued on next page)

Messages

Menu Messages | Menu Messages are below each letter of the 4 Menus used in **ChEc**. The first letter of the Message always corresponds to the flashing letter of the Menu.

Main Menu

MC P

From here you can Program a Race, set your Calibration, or look up Info from the last Race.

PrO

From here you can move into the Program section of **ChEc**.

CAL

Adjust your Wheel Size or switch to Metric operation from here.

InFo

Info from the last Race is stored here, such as the AutoCal Wheel Size, your top Speed, the ground distance of the Race, and the cumulative distance on your instrument.

Race Menu

cFrS

You will loop thru this Menu after each time you enter a line of Race Data, such as a Speed change.

SPEd

SPEd - Select this Message to enter a Speed Change.

rSEt

rSEt - Here is where a Reset is entered.

FrEE

FrEE - Free Times are entered here.

cont

cont - Known Controls can be entered here (optional)

(Continued on next page)

Messages

d A Menu



From here you can delete a single line from your Program, or Add lines to your Program.



You can Add a new line to your Program.



Or you can delete a SINGLE line from your Program. Deleting the entire Program is done from another point.

Y n Menu



yES or **no** Menu, which follows several decision points.

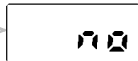

Selecting this message allows you an ESCAPE route and moves you back to the starting point.

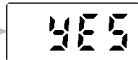

Select this to perform the action & move to the next step.

Moving thru ChEc

Remember, you can only move into **ChEc** while at Ready. Once you are in **ChEc** you can load or delete a Race Program, **CAL**ibrate your wheel size, or lookup **InFo** from your last use. Let's start bumping buttons now.

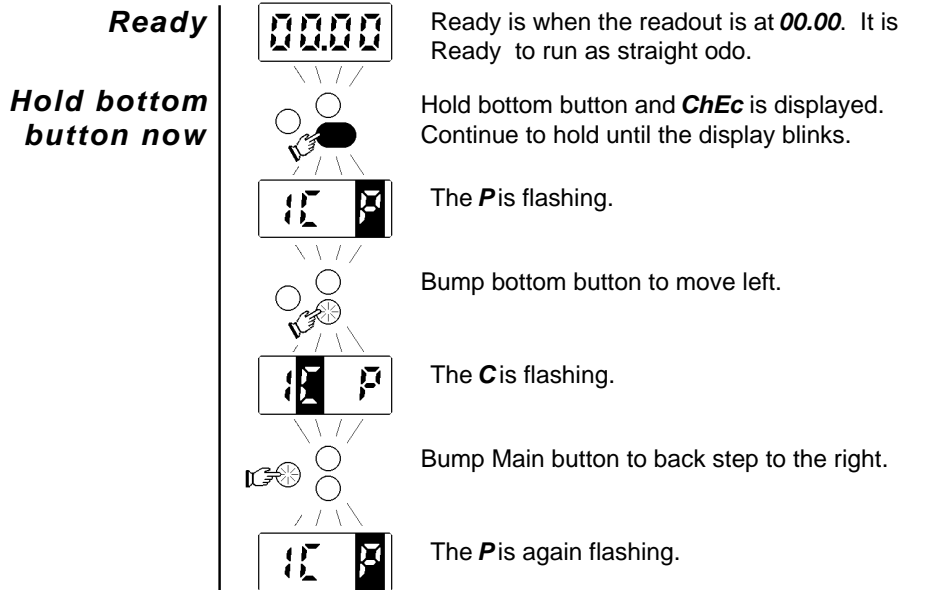

Any time a digit is flashing in **ChEc**

Bumping the bottom button moves left

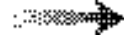
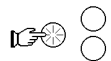

..... and bumping the Main button moves right.

(Continued on next page)

Moving thru ChEc

Remember, you can only move into **ChEc** while at Ready. Once you are in **ChEc** you can load or delete a Race Program, **CALibrate** your wheel size, or lookup **InFo** from your last use. Let's start bumping buttons now.

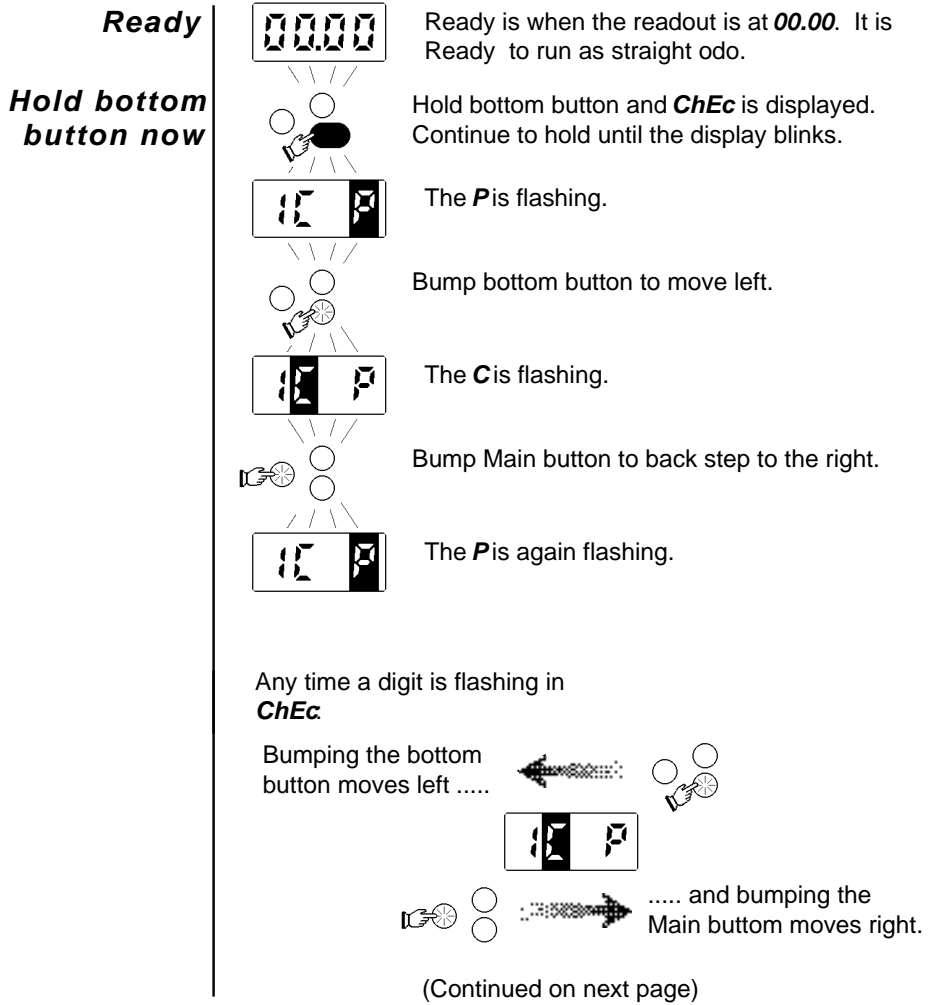

Moving thru ChEc

The other type of readout is the non-flashing readout.

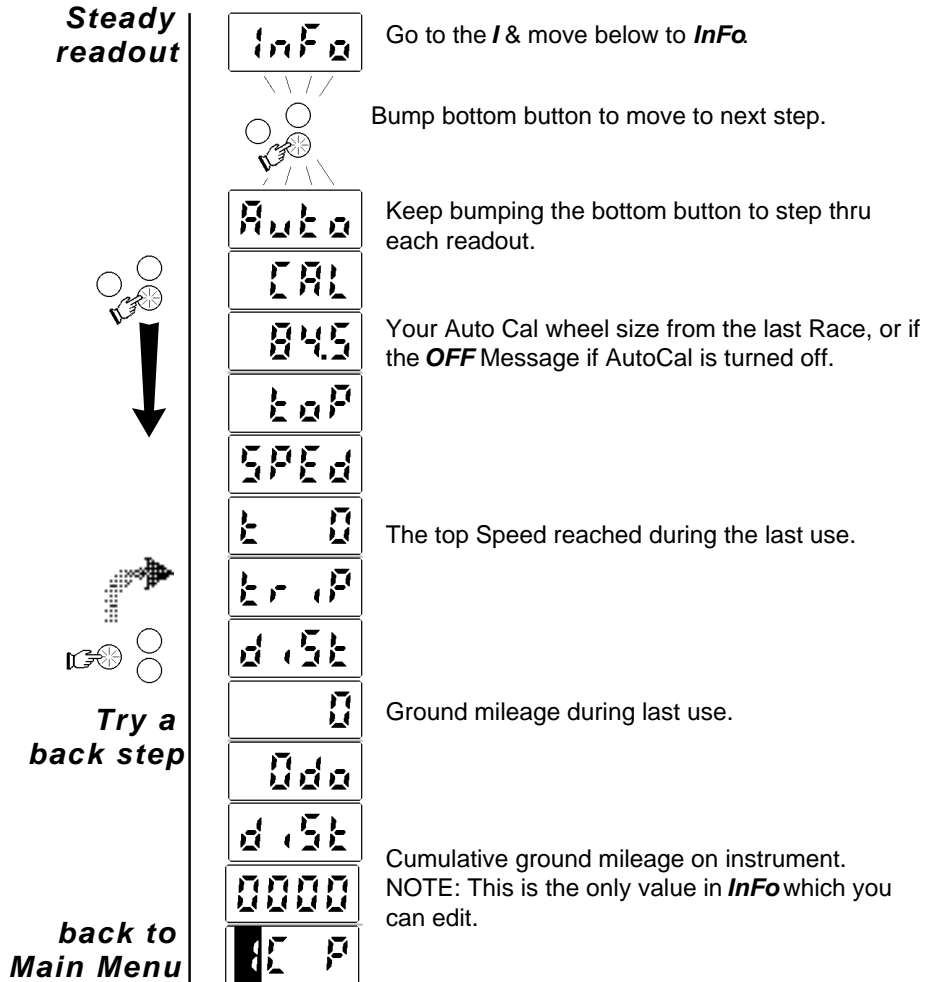

(Continued on next page)

Moving thru ChEc

**Steady
readout**

While at a steady readout, bumping the bottom button ALWAYS moves you to the next readout.



Bump bottom to move to next readout.

Out of ChEc

How do you get **Out of ChEc**?

At ANY point in **ChEc**, long holding the Main button moves you **Out of ChEc** and back to Ready, even half way thru Programming.

*No matter how lost you may become, remember that holding the Main button will ALWAYS get you **Out**.*

Back to
Ready

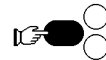

Long hold Main
at ANY readout.

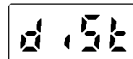

(Continued on next page)

ChEc Summary

at any flashing readout

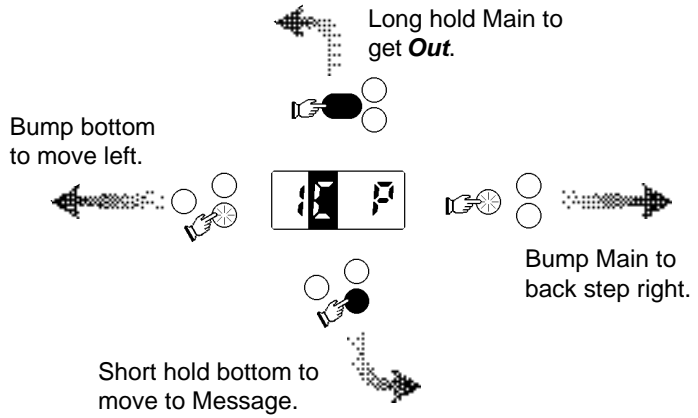

at any steady readout

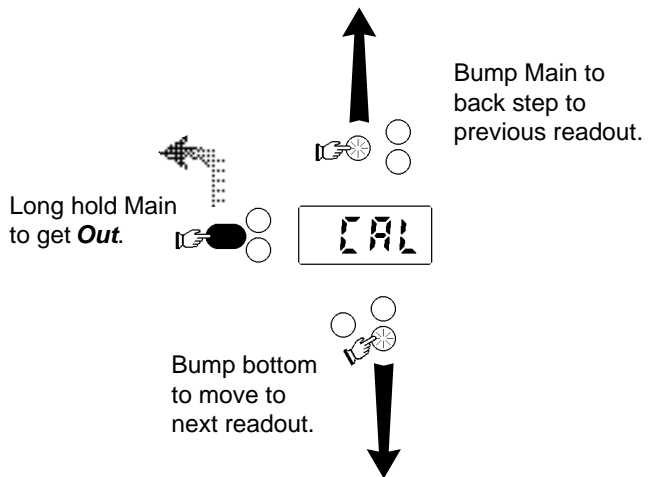

Moving into Programming

Let's begin to Program a simplified Race. Move to **Pro** below the **IC P** Menu. The next readout you come to is the Ahead value. This is the number of minutes Ahead you wish to start your instrument at the starting line. As an example, with **A 01** you would start your instrument exactly when the row ahead of yours leaves the Start. Your instrument would count down for 1 minute, then automatically begin to run at the first Speed you have entered.

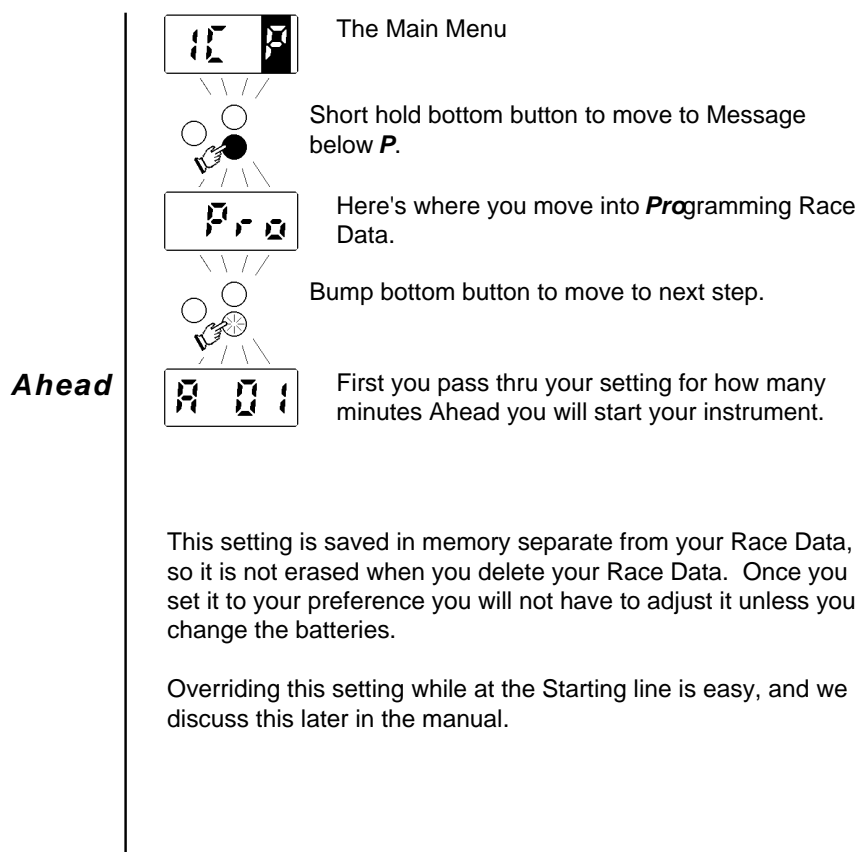

Changing any number

Changing any value is easy - simply bump the top button while a number is being displayed. A flashing digit means you can edit that digit. Once the full value is what you want, a short hold of bottom enters the value into memory & puts you into Final View.

Changing a number



The value is **01** but you may want **03** . Any value from **00** to **99** minutes can be entered.



Bump top button to start the far right digit flashing.



The **1** is flashing.



While any digit is flashing bumping the top button increments the value by 1. Bump twice.



The **3** is flashing. Now we are ready to enter the full value **03** .



We enter **03** by a short hold of the bottom. Note the display blinks, then becomes steady.

Final View



03 has now been entered. We call a steady readout with a number the Final View.

Summary, Flashing Readout

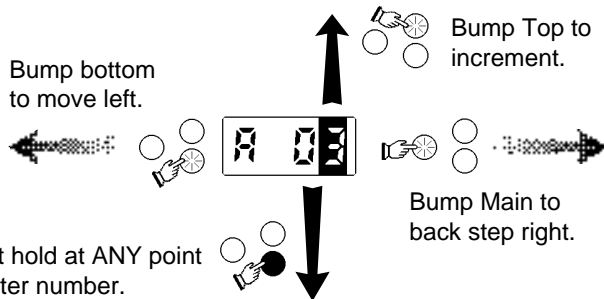

Program Map

Next we'll get into entering Race Data. It's a snap - you enter each line of Race Data *as it occurs*. After each entry of a line of data you will be returned to the Race Menu for your next selection. Once you have entered all lines simply get **Out**. You can come back at any time & review or edit any line of your Race Data. The entry steps are:

- 1) Select what takes place - Speed change, Reset, Free time or Known control.
- 2) Enter the Mileage where it occurs.
- 3) Enter the value associated with that entry (Speed average, Free minutes, etc.)



If a Speed change & a Reset (or LEAP) occur at the same Mileage, ALWAYS enter the Speed change 1st. Then enter the Reset (or LEAP) as the next line.

Race Menu

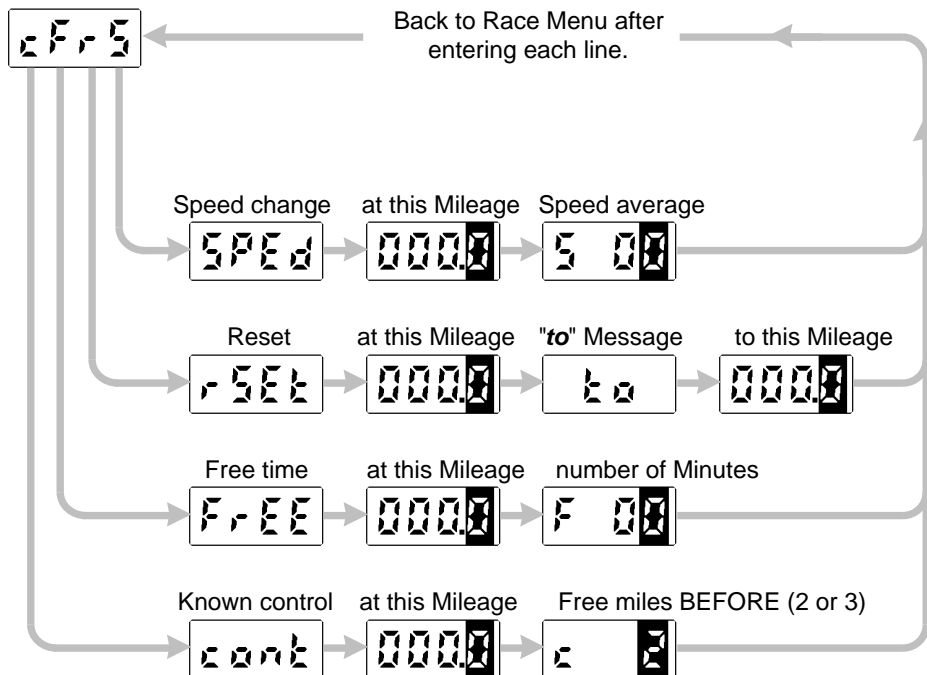

Error checking

One of ProComp's most powerful features is its ability to warn you of entry errors during Programming. To make sure you are entering data which will run properly, your instrument will check each entry. If you violate any of the following items, an error message will flash on your readout. Simply back step into your entries, determine what is at fault, correct it, then return to entering your data.

Below is what ProComp checks for:

Error checking

- 1. The first line entry must be a Speed average.*
- 2. This first Speed entry must be at Mileage **000.0***
- 3. A Speed of **00** is not acceptable.*
- 4. Each Speed change or Reset to **000.0** must occur at a possible check location.*
- 5. All lines must be entered in the order which they occur.*
- 6. Each Mileage you enter must be equal to, or greater than, the previous Mileage entry. (The only exception is a Reset to **000.0**)*

These checks are intended to assist you in entering a correct Program. It's not very pleasant having your race ruined by a mistake in your Race Data. By checking the above items, ProComp will catch the vast majority of errors, such as wrong Speeds, Speed changes at the wrong Mileage, forgetting to enter a Speed change, etc.



There may be some legitimate circumstances where a Race is run with data which violates the above rules. If you are positive you wish to ignore the Error Message, by all means do so. ProComp will attempt to run using the available data.

Programming Race Data

O.K. - Let's jump into Programming a Race. We'll do a very simple Race:

Sample Race

Speed at	000.0	Start at	24 MPH
Reset at	5.0	to	5.1
Speed at	6.4	change to	20 MPH

Race Menu



Go to the Race Menu & short hold the bottom button.



A Speed must be the 1st entry



..... *and* it must be at **000.0** Short hold bottom button to go to Final View.

Final View of 000.0



Bump bottom to move to the Speed average.



Adjust to **24**



..... then short hold bottom button to enter **24**

Final View of 24



Bump bottom to move to the next step.



Race Menu - Now bump bottom to move left.



The *r* is now flashing. Short hold bottom to



..... select Reset. Bump bottom to move to next step.



Bump bottom to move left, then bump top



until the digit reads **5** Short hold bottom to.....

Final View of 005.0



enter **005.0**

(Continued on next page)

Programming Race Data

*Final View
of 005.1*

*Final View
of 006.4*

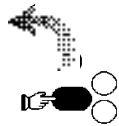

*Out of
Programming*

Ready

005.0

Bump bottom button to move to next step.

to

You are between the 1st & 2nd halves of the Reset.

005.0

2nd half of the Reset. Adjust to **005.1**

005.1

..... then short hold to enter **005.1**

005.1

Now bump bottom to move to next step.

cFr5

Bump Main to move right

cFr5

..... then short hold bottom to select **SPEd**.

SPEd

Bump bottom to move to next step.

005.0

Note how it picks up at the Mileage of the last entry. This makes it easy to keep track of where you are in your Program. Adjust to **006.4** then short hold bottom to enter **006.4**

006.4

Bump bottom to move to next step.

006.4

5 24

Note how it picks up at the last Speed entered.

5 20

Adjust to **20** then short hold bottom to enter **20**

5 20

Bump bottom to move to next step.

cFr5

Since a Speed of **20** is your last entry, you end Programming by getting **Out**. Long hold Main to get **Out** of Programming.

03:00

Programming complete!
Ready to start a Race, with 3 minutes Ahead, but don't start it now. We'll check it first!

Checking Race Data

Your ProComp is ready to start running, but first let's check your **Program**.

**Main Menu
with a d**



**Try several
back steps**



Note that a **d** has appeared. That's where you go to **dELete** all of your Race Data. But for now we will check the sample Program we have entered.

Just keep bumping the bottom button to go to next readout.

At any point you can bump Main to back step. Try it several steps in a row, then bump bottom button to resume stepping in the other direction.

With this sample Program your instrument would continue to run at 20 MPH until **Shut OFF**.

End of your Race Data.

Back to the Main Menu.

(Continued on next page)

Checking Race Data

There are 2 other great features of check which make Programming easier.

Automatic scanning



10 d P

Pro

A 03

SPEd

0000

5 24

-5Et

0050

to

005.1

Scanning can be started from any point in **Pro** or **InFo**, even from the flashing **P** or **I**. Here's how: KEEP holding the bottom button until the 2nd readout is displayed, then release. ProComp goes into automatic scanning of each readout, approx. 2 seconds each. This should be enough time for hands-off checking your Program against the race sheet.

Try it now.



Stop scan here

Bump ANY button to stop at a specific readout.

Bump top to change a value



005.1

005.2

Let's say we wanted **005.2** instead of **005.1**. Simply bump the top button while at any number to edit that value. Try it now. Adjust to **005.2**, then short hold bottom to enter **005.2**

005.2

Bump bottom to go to next readout.

SPEd

A Speed change is the next line of your Program.

Mileage at a fractional tenth

Some Races may have Resets, Free time or Gas Stops at Mileages which are not on a whole tenth (.1) Just keep bumping the Main button to scroll the readout to the far right.

.XX Mileage



Let's say you wish to enter **02.25** and you are at **002.2** with the far right **2** flashing.



Bump Main button.

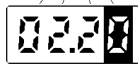

Note that the entire readout scrolled to the left, allowing access to the far right digit.



Adjust to **02.25** and short hold bottom to enter value.

Once a scrolling value is entered, each time you step thru that value it will display the 4 far right digits for about a second, then it will scroll to the right for the Final View. Try it.



Be sure NOT to round off fractional Reset Mileage to the nearest tenth. It will have an affect on AutoCal accuracy.

Programming

LEAP

A **LEAP**, which is an instantaneous jump in Mileage, is used during Programming to handle 2 unusual circumstances:

1. A Speed greater than 99 MPH.
2. Races which have **LEAP**'s in their Race Data.

Speed above 99 MPH

You may have to do some calculations first. Let's say a club has a 120 MPH section for 2 minutes, which begins at 12.4 miles.

Determine the starting (012.4) & end (016.4) Mileage for the section, plus the number of minutes in that section.

Step 1 - Enter a **LEAP** from the start Mileage **to** the end Mileage.

Step 2 - Enter **FrEE** time of how many minutes you should be in that section.



ProComp will **LEAP** this section during the Race, so your Late/Early & Mileage readouts will be inaccurate while in this section. Once you are out of the fast section you **MUST** manually adjust your Mileage **BACK** to 16.4 miles. All readouts will be accurate once you adjust Mileage & leave that section.

THIS IS EXTREMELY IMPORTANT!

Races with a LEAP

These are simple, just enter a **LEAP** from the start Mileage **to** the end Mileage, such as LEAP from **006.0 to 008.2**

How to go to LEAP

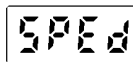

Select the Message **SPEd** while entering new data.



Hold the top button while the Message **LEAP** scrolls across the display.

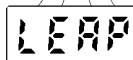

Here's where you enter a **LEAP**.



LEAP's are NOT intended for Resets to **000.0**.

Known controls (Optional)

Timed checkpoints, including Known Controls, cannot be located closer than 3 GROUND miles apart. Therefore 3 ground miles before, and 3 ground miles after a *timed* checkpoint can be considered Free Zones. Similar Free Zones may apply to Gas Stops, usually with *timed* checks no closer than 2 miles before, or 3 miles after the Gas Stop.

ProComp allows you to enter Known controls into your Program, either a 2 or 3 mile before **control**. 3 miles after is automatic, so no entry is needed. It then uses this information while calculating next Possibles during the Race, adding a 5 or 6 mile Free Zone around each Known control.

Race Menu

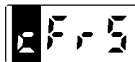

Select **control** from the Race Menu.



Bump bottom to move to next step.



The only options are 2 or 3 miles BEFORE a Known **control**.



Although entering controls only affects the next Possible calculations while running a Race, you have to be careful. The rules on Known **controls** vary from region to region.







Be sure to check with the club at each race, and only enter controls after you are certain of the rules for that Race.

A review of some GENERAL guidelines:

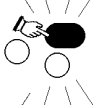
1. *Timed checks cannot be located less than 2 miles BEFORE most Gas Stops. (Gas available usually is not a Known), or 3 miles BEFORE other Known controls.*
2. *Checks cannot be located less than 3 miles from the Start.*
3. *Known controls have to be declared as such by the club. If not declared, DO NOT make any assumptions. Check with the club.*

Adding a single line

You can easily **Add** a line to your Race Data. Let's say a last minute Reset, 6.0 to 6.2, has been added to the Race. Just go to ANY point in the line which is just BEFORE where you wish to **Add** the new line, and long hold the Top button. The new line will be **Added** just AFTER that line.

		Stop at ANY point in the line rSEt ... 005.0 ... to ... 005.2 (Remember we changed 005.1 to a new value, 005.2)
		Long hold the Top button.
d A Menu		The dELete/Add Menu. Short hold bottom to select Add .
		This is what we want.
Y n Menu		yES/no Menu. If you select no you will go back to checking.
		Bump bottom to move left, then short hold
		bottom to select yES .
Race Menu		Bump bottom to move to next step.

ProComp brings up the Race Menu to allow you to Add a line at this point. Select **rSEt**, then enter **006.0 to 006.2** You will then be returned to the next line in your Race Data.

		You are now at the line SPEd ... 006.4 ...
		S 20 Back step up thru your Race Data and you will see that the new line has been Added .

Resume Programming If you **Add** from the **End** Message you are returned to the Race Menu after entry of each line. This feature allows you to enter a partial Program, get **Out**, then go back in to resume Programming.

Deleting a single line

You can also **dELete** a single line from your Race Data. Let's **dELete** the Reset, 6.0 to 6.2, that you have just added. Just go to ANY point in the line which you wish to **dELete**, and long hold the Top button. The line you have selected will be briefly displayed, then the **yES/no** Menu will appear.

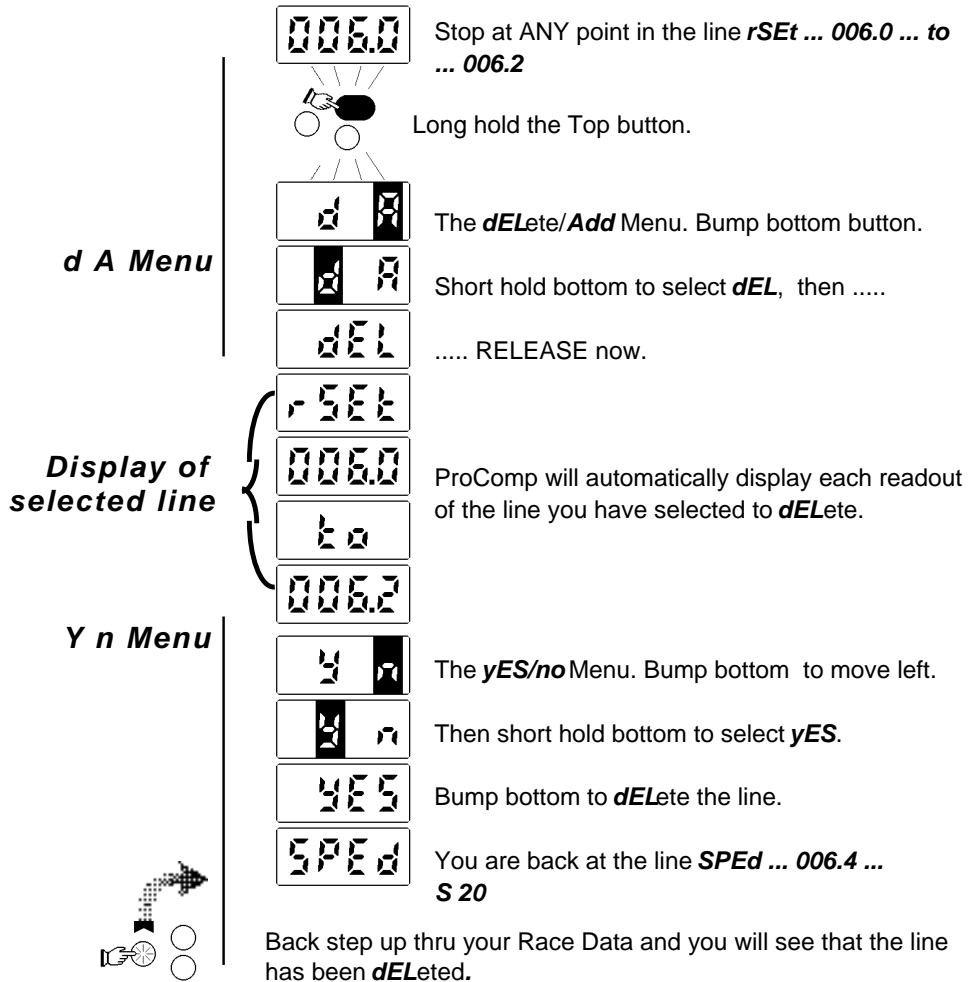

FULL

ProComp will accept up to 42 lines of Race Data. If you have one of those very rare Races which exceeds this number, do the following:



You have entered 42 lines & the memory is ***FULL***

Review your Race sheet and determine how many lines you need to enter ALL items. As an example, lets say you have 45 lines of Speeds, Resets, Free time & Known controls. (Your Ahead setting is separate & does not count as a line). You will have to scratch out 3 lines.

- *The first item you should eliminate should be Known controls, since they do not affect the basic running of the instrument.*
- *If you still have more than 42 lines then eliminate Resets, starting with the LARGEST Reset on your sheet. Eliminating a large Reset will not affect AutoCal, whereas a very small one may affect calculations. Of course, while running the Race you will have to manually adjust your Mileage when you arrive at these missing Resets.*
- *Continue to scratch out Resets, each time selecting the largest, until 42 lines remain.*



NEVER leave out Speed changes or Free times! Doing so will cause the instrument to run at a different rate than that of the Race.

Deleting an entire Race

Before you can enter a new Program, you must first **dELete** the entire old Program which is in memory. Go to the Main Menu.



Bump bottom to move left

..... then short hold bottom to select **dEL**.

Bump bottom to move to next step.

dELete Program.

The **y n** Menu. Bump bottom to move left

..... then short hold bottom to select **yES**.

Whoa! If you bump bottom here your entire Race will be **dELeted**. You may not wish to do this.

To back away you could back step from here. Try it, then go back to the **yES** Message and **dELete** the **Program**.

Back to the Main Menu with no **d**
From here you can get **Out** or enter a new **Program**.

Just your Race Data has been **dELeted**, not your Ahead setting, your **CAL** settings, or any values in **InFo**.

Sample Race #2

For the next chapter we'll need a sample Program. Enter a Program for a straight 24 MPH, with a Gas stop at 050.0

SPEd ... 000.0 ... S 24

cont ... 050.0 ... c 2

Also change the Ahead from 3 minutes to 1 minute.

How to use ProComp in a Race

Now we'll see how the whole system comes together. Many of you will be content with staying at the Late/Early readout, with only an occasional switch to check your Mileage at each Mileage marker, while others will jump into the more advanced features, such as entering Known controls, lookup of next Possible and Marking controls.

Here's some tips on getting the most from your instrument during a Race:

Thumb Switch

The Thumb Switch is a vital part of the system. Be sure to carefully position it so that your thumb easily drops right into the Main button pocket. The base of the Thumb Switch can be flipped to allow mounting to either side of your lever perch.

Late/Early readout

Once ProComp has been started & is running, it automatically goes to the Late/Early readout. This is your variance, in minutes & seconds, from a perfect schedule. You will probably leave it on this readout for most of the Race.

coming into timed checks

Late/Early is very useful for pacing, but it is NOT what you want to use for coming into a check. Let's use the example of running a 24 MPH Race PERFECTLY ON SCHEDULE for the entire event. Your Late/Early readout would stay on :00 during the entire Race. If you come into a check which is located 1 tenth of a mile off, with the error moving the check closer to the start, you would be marked 15 seconds early even though your Late/Early reads :00. Look at the 2 examples below, #1 has the check .1 off & #2 has the check spot on. Note how your Late/Early for both would read perfectly on schedule.

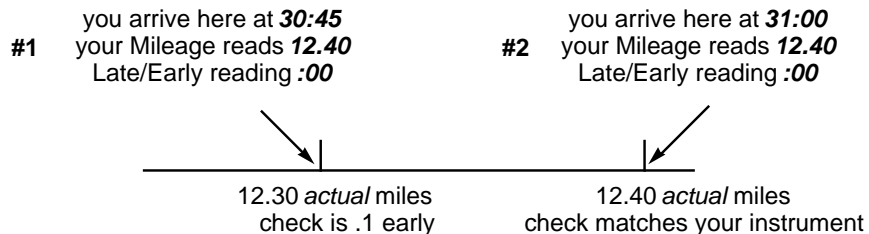

(Continued on next page)

How to use ProComp in a Race

switch to Seconds	The solution is to switch to the Seconds readout. It has features which tell you if you are early, "in your minute", or out of your minute. Naturally, if your Late/Early shows more than 1:30 behind schedule, just forget about timekeeping & gas it into the check.
Mileage markers	ALWAYS switch to Mileage readout at each Mileage marker & adjust if necessary. To do so each time you see a marker, bump the Main button 2 times, then check your Mileage readout. Adjust if necessary using the top & bottom buttons, then bump the Main button to return to the Late/Early readout. (Be sure to read the About AutoCal section of this manual)
next Possible	This is great! At any time just hold the Main button & the ground distance to the next Possible is displayed. Be sure to read the page covering this feature.
Marking a check	Here's an optional feature for the more advanced rider. While being scored in a <i>timed</i> check, holding the Main button will Mark that Mileage as a check location. This will add the 3 mile free zone to it's next Possible calcs.
switching readouts	A technique to practice while using the Thumb Switch is to delay looking at the display until you have finished making your switch. As an example, your readout is on Late/Early and you come to a Mileage marker. Simply bump the Main button twice, THEN look down at the readout. This saves precious seconds in a Race.
Lookups	You can peek at the Speed average of your current section, the wheel size the instrument is using, and full minutes & seconds.
Speed & top Speed	You can also switch to a readout of your current Speed & your top Speed.
	Don't forget: <ul style="list-style-type: none">• Always switch to the Seconds readout while entering a check.• Always check your Mileage readout at each Mileage marker.

Overriding your Ahead minutes

After each use you should **Shut** your instrument **OFF** to prolong battery life, so let's pick up from that point. We'll turn it on, look at overriding your Ahead minutes while at the starting line, then we'll **Shut Off**.

NOTE: The following pages assume you have entered a sample Race with **SPEd ... 000.0 ... S 24 & cont ... 050.0 ... c 2** entered, plus Ahead is set to 1 minute.

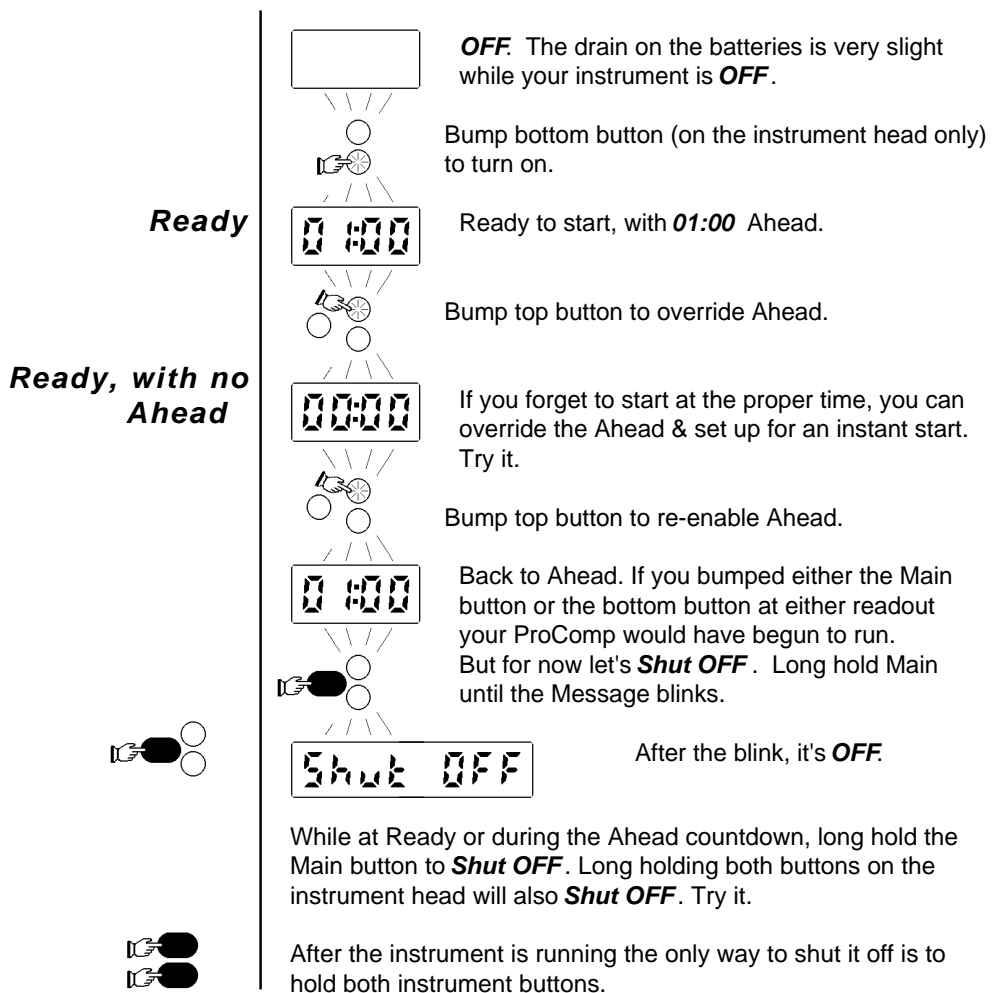

Starting

Now we'll look at starting ProComp. Once started, it will countdown from how many minutes Ahead you have it set to, then automatically begin running using the Race Data you have entered.

Easy to start
..... just bump any of these



We made it easy to start - Just bump the Main button, or either of the bottom buttons.



or



or



The entire readout is flashing as the ProComp counts down to the exact time your row should leave.

If you wish to **Shut OFF** while in the countdown, long hold the Main button. But for now just let it keep running.

countdown



The countdown will continue until it reaches 00:00

Race Mode



..... then ProComp will automatically go to the Late/Early readout & begin to run the Race Data you have entered. We call this the Race Mode.

Switching Readouts

ProComp has 3 primary readouts while running in Race Mode:

- *Late/Early - Minutes & seconds variance from a perfect schedule.*
- *Seconds only - Used for coming into checks at the desired time.*
- *Mileage - Switch to here to make sure you are matching club markers.*

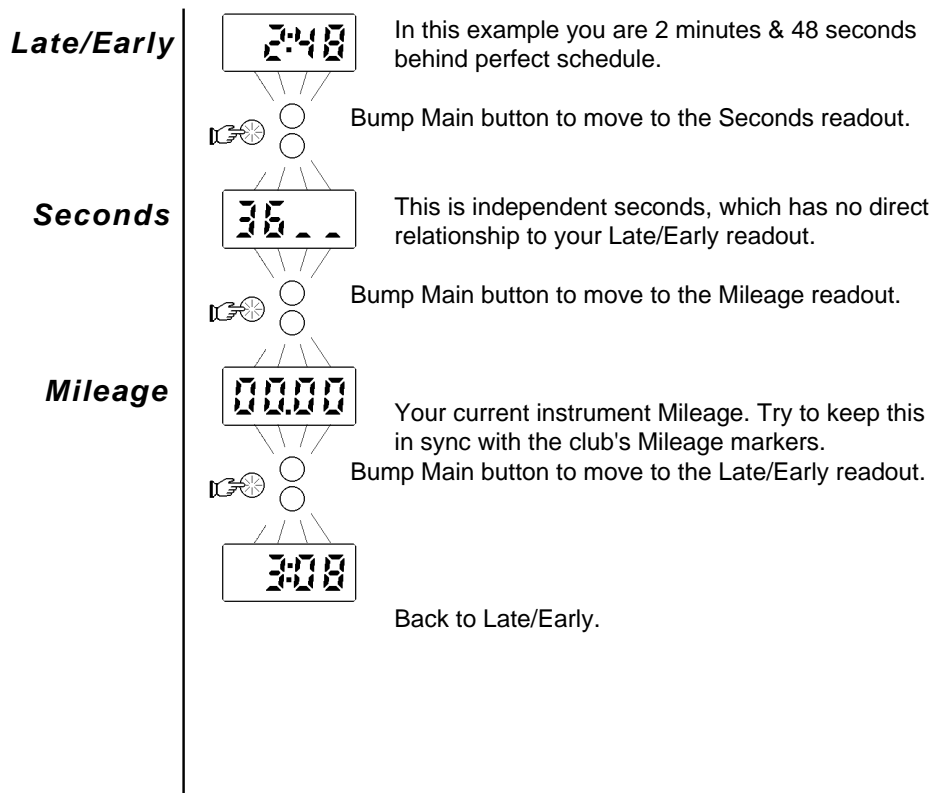

Late/Early readout

Here's the primary readout which is the heart of the system, and you will probably leave your ProComp on this readout for most of the Race. It's your variance, in minutes & seconds, from a perfect schedule. If you are on time (Top of your minute) the readout will be *:00*. The readout flashes when you are early, and it's steady when you are on time or late.

You're late!



3 minutes & 46 seconds behind schedule. The readout is steady, indicating that you're late.

Move ahead in this manual to the Mileage page, then switch your instrument to Mileage readout. Increment the Mileage to around *05.00* miles then switch to Late/Early readout. The readout should be flashing, indicating you are ahead of schedule.

You're hot!



9 minutes & 58 seconds ahead of schedule.

There are also 2 secondary lookups while at this readout:

- *The Speed average of the section you are in.*
- *The AutoCal wheel size ProComp is currently using.*



9 minutes & 45 seconds ahead of schedule.



Long hold top button for the Speed average of your current section.

**Speed
average**

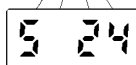

The Speed average for the section you are in.



Continue to hold for the AutoCal wheel size.

**AutoCal wheel
size**



The wheel size ProComp is currently using.
(See about AutoCal)

Seconds readout

The Seconds readout displays the current independent seconds, much the same as a regular clock would. It also indicates if you are hot, "in your minute" or "out of your minute". If your Late/Early readout is less than 1:00 late while entering a *timed* check, switch to the Seconds readout.

You're hot!



The readout is flashing & just the top ticks are turned on. You are either 8 seconds, or 8 seconds + some minutes, before the time your minute rolls over. Don't enter that check!

in your minute



This example is a perfect 30 seconds into your minute, just right for an Emergency (Tie-Breaker) check.

out of your minute



You are "out of your minute", hurry into the check!



If your Late/Early readout is less than 1:00 late while entering a timed check, we strongly suggest that you use this readout. The Late/Early readout is NOT the one to use for going into a check.

There is also a secondary lookup from this readout:

- The full minutes & seconds from the time your row left the start.

NOTE: There will be a 30 minute difference between your clock & Races which start at 7:30. If you use a roll chart, be sure to obtain one which is corrected to start on the whole hour.

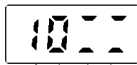

Long hold top button for full minutes & seconds.

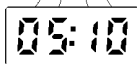

The full minutes & seconds from the start.

Mileage readout

While in the Mileage readout, either in a Race or as a straight odo, you can manually adjust the value so that it matches the club's Mileage markers. Be sure to read the "about AutoCal" section of this manual, it contains important information on how to get the most from AutoCal.

Mileage readout



You have not traveled any distance yet.



Bump top button to increment by *.01*



One hundredth of a mile.



Long hold top to fast increment.



Twenty-eight hundredths of a mile.



Bump bottom to decrement by *.01*



Long hold bottom to fast decrement.



Back to Zero.

There are 2 features which make adjustments easier.

The increment/decrement has 2 speeds - It adjusts slowly for the first few seconds, then speeds up if you continue to hold. Also, if you fast increment/decrement into a Reset, the readout ends the adjustment at that point.

About AutoCal™

In the world of Enduros there are 3 kinds of Mileage:

1. Absolute Mileage (Exactly 5280 feet).
2. What your instrument reads.
3. What the club says your instrument should read.

The goal is to get #2 to match #3 throughout the entire Race.

To achieve this goal, ICO introduced it's **AutoCal** odometer in 1988. Since that time we have made several improvements, and have included this enhanced **AutoCal** in your ProComp.

When does it work?

• **OFF** all of the time.

If you set AutoCal to OFF at **CAL** (See next Page), or if you're running as a straight odo, AutoCal remains OFF during use.

• **ON ONLY** around each 2.9 mile marker.

True if AutoCal is ON at **CAL**, but you have NO Resets entered in your Program. It's ON at each 2.9 marker, OFF anywhere else.

• **ON** throughout the entire Race.

AutoCal is ON at **CAL**, and you have entered at least 1 Reset into your Program.

How does it work?

AutoCal measures the difference between your readout and the Mileage markers throughout the entire race, and then re-calibrates when necessary to match the bike used to layout the course. An added bonus is that it also corrects for other factors, such as slippery conditions or how aggressively you scrub distance each time you aggressively use your front brake.

Programmed Wheel Size

ProComp leaves the start of each Race using the Programmed Wheel Size you have entered in **CAL** until you make your first manual adjustment. After you complete this first adjustment, **AutoCal** performs a series of calculations which creates a new wheel size factor, the AutoCal Wheel Size.

(Continued on next page)

About AutoCal™

It uses this new AutoCal Wheel Size until the next manual adjustment, where it again calculates and creates a new AutoCal Wheel Size. It repeats this cycle each time you manually adjust the readout.

Manual Adjust Mode

You enter the Manual Adjust Mode in 1 of 2 ways: Setting a control, or pressing either a top or bottom button while at Mileage readout. This is different from the normal Mileage readout in that any distance accumulated if you are rolling is not added to the readout, but is put into memory. Not adding to your readout while rolling simplifies adjusting without coming to a complete stop at the marker.

Mileage readout

You exit the Manual Adjust Mode in 1 of 2 ways. You can either bump the Main button to switch to Late/Early readout, or simply do nothing. If you do nothing, ProComp returns to the normal Mileage readout after 10 seconds of NO button activity. It will blink, then add the distance you may have rolled during the manual adjustment. You are then back at the normal Mileage readout. Either way any roll distance is added to your Mileage.

Accuracy

For the best accuracy, BEGIN making your manual adjustment as soon as you are alongside a Mileage marker, NOT before or after you have passed. You have plenty of time to complete the adjustment, even if you continue rolling down the trail.

Changing batteries

AutoCal is automatically set to ON when new batteries are installed. It remains set to ON unless changed as noted below.

AutoCal On/Off

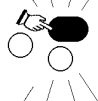

To toggle AutoCal between ON or OFF, stop at the **Cal** Message under the **C** in the Main Menu. Then long hold the top button. The Message **Auto CAL** will scroll across the display.

Keep holding while the Message is scrolling across the display.

Y n Menu



yES/no. Select **no** for OFF & **yES** for ON.

About *AutoCal*™

Below are some **DO'S** and **DONT'S**, along with a warning, which will help you to enjoy the maximum benefits *AutoCal* has to offer.



BEGIN your manual adjustment as soon as you are right **ALONGSIDE** the Mileage marker.
END each manual adjustment with the **EXACT** Mileage which is on the Mileage marker, regardless of how far you may have rolled past the marker during the adjustment.
BE SURE not to allow more than 10 seconds between bumps of the buttons. Remember, the instrument automatically returns to the normal Mileage readout after 10 seconds of **NO BUTTON ACTIVITY**.

Peek at wheel size

To peek at the wheel size ProComp is currently using in a Race, long hold the top button while at the Late/Early readout. 1st your current Speed average will be displayed, then the wheel size.



DO NOT guess at the Mileage if you become lost on the trail. Wait until you come upon a marker before you make a manual adjustment. Safeguards are built into *AutoCal's* logic which prevent false calibrations due to problems such as this.



If you **DO NOT** have any Resets in your Program, automatic calibration will occur **ONLY** around each 2.9 marker. You may continue to make manual adjustments at the other markers, however, automatic calibration will be turned **OFF**.
Why? *AutoCal* cannot distinguish between an intentional Reset and a Mileage error unless you tell it where the Resets are by loading them into memory.

Races with no Resets

To enable automatic calibration throughout the entire race, enter a false Reset, well beyond the Finish, with both halves the same. I.E.: 200.0 to 200.0

a Final Word

As precise and sophisticated as *AutoCal* is, occasionally you may run events where your readout has consistent errors in **BOTH** directions. The cause is probably erratic Mileage marking by the club, a problem which no instrument can resolve.

Next Possible

Another feature you will find extremely useful is the Next Possible readout. Long holding the Main button at any point in the Race looks up the Ground distance to the next Possible.

**any of the 3
readouts**



Late/Early, Seconds or Mileage readout.

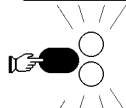

Long hold the Main button while at ANY of the 3 readouts.

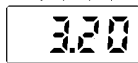

The GROUND distance to the next location where a *timed* check can be located.

ProComp will display how far you can roll before you arrive at a Possible. Let's use a simple Race as an example, one run at 24 MPH. If you were at **44.82** miles & you held the Main button, **.38** would be displayed.



A Reset, or several Resets, may be located between your current Mileage & the next Possible. If so, these are automatically subtracted from the next Possible ground distance.

(Continued on next page)

Next Possible

Known controls

If you have Known **controls** entered into your Program, they are used in the next Possible calculations. NOTE: ProComp does not treat a Known control as a Possible, since you are allowed to enter the control up to 15 minutes early.

You are at 48.10 miles

If you had entered a 2 mile **cont**(Gas) at 50.00 & you were at mile 48.10, long holding the Main button would display a readout of **5.10** Why? Once you pass 48.00 you have a minimum of 5.0 miles before another Possible could occur.

In our example, the earliest a *timed* check could occur after the Gas would be at 53.20. Hence, $53.20 - 48.10 = 5.10$.

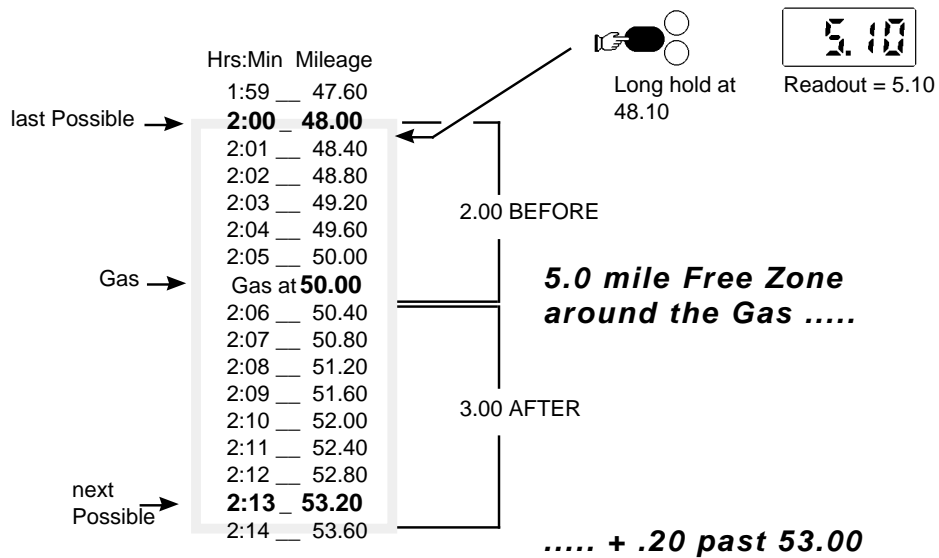

Of course this is a very simple example. Many Races have Resets or Speed changes which occur inside of the Free Zone. ProComp will take care of all of these for you.

Marking a control

This feature will be hard to explain, yet easy to use. Before going any further please read the "About AutoCal" section of this manual. It discusses several keys points needed to fully understand topics in this section.

O.K. While you are in a timed check, you can actually have ProComp mark the Mileage as a check location. It then adds 3 miles of Free Zone to it's next Possible calculations.

The following example has you coming into a check at 8.40 miles, with your readout currently switched to Seconds. Your instrument Mileage in our example is at 8.38.

any of the 3 readouts



You are in a check, our example is at 8.40 miles. Plus it looks like you came in on your minute.



Long hold the Main button to display next Possible.



Since you are at 8.38 & the next Possible is at 8.40, your next Possible readout will be .02



Continue to hold the Main button.



The moving Message **cont** scrolls across the display.



Continue to hold until the **cont** Message blinks.

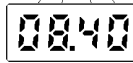

ProComp has snapped automatically to the NEAREST Possible, so in most cases no adjustment will be needed. You are now in the Manual Adjust Mode discussed in "About AutoCal", however, the check is still not marked yet!



BE SURE to thoroughly read the next page!

Marking a control

The check is marked only after either of these 2 actions:

Switching to Late/Early

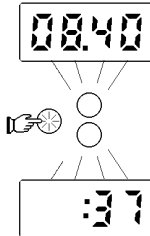

You have 10 seconds to either switch to Late/Early, or to BEGIN adjusting to a different Mileage. Bump the Main button if your Mileage matches. ProComp then accepts **08.40** as a check location, adds any roll distance and switches to Late/Early readout.

Check Marked! The time spent in the check put you about 37 seconds behind perfect schedule.

going for 10 seconds without any switch activity



Your 2nd choice is to do nothing. After 10 seconds ProComp exits the Manual Adjust Mode. The display will blink, any roll distance you may have accumulated will be added, and you will be returned to the normal Mileage readout. The check is now Marked at **08.40**.



We have automated this process to save you as much time as possible, but it is your responsibility to make sure that your readout matches the marker. If it does not match, you MUST BEGIN to adjust before your 10 seconds are up!

THIS IS VERY IMPORTANT!

If you fail to do so, you will leave the check with your instrument set to the incorrect Mileage!

Run thru several examples at this time so you can get comfortable with Marking a check. You'll see that it is a lot harder to explain than it is to actually do!

Current Speed & top Speed

At any time in a Race you can switch to a readout of your current Speed or your top Speed. This is handy if you spot a Smokey with a radar gun on the side of the road. Just bump the Main button to return to the Race readout from which you switched.

**any of the 3
readouts**



Switch to current Speed from any of the 3 primary readouts. Late/Early is our example.



AND  Bump the Main button AND the top button on the instrument.



Your current Speed.



Bump Main button to display your top Speed.



56 MPH (or KPH) is the fastest you have gone.

While your top Speed is being displayed, you can bump the Main button to return to the Race readout from which you switched, or you can long hold the top button to Clear your top Speed.

**Hold top to
clear top
Speed ...**

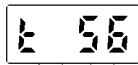

Long hold top button to clear top Speed.



Top Speed is now **00**. NOTE: It may remain **00** even if you are currently rolling. Once you drop to a slow speed, then accelerate, it will capture your latest top Speed.

**... or bump
Main to switch
back**



Back to Late/Early readout.

Pro3 mode

At any time during a Race you can switch to Pro3 operation, which has 2 readouts: your "should be" Mileage and a clock.

any of the 3 readouts



You must long hold the Main & both instrument buttons. The **Pro3** Message will scroll.



AND



Long hold the Main button AND both buttons on the instrument.

Pro3 mode

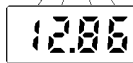

This is your "should be" Mileage for that instant in the Race.



Bump Main button to switch to clock readout.

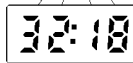

A clock of minutes & seconds from the time you row left the start.

You can long hold the Main & both instrument buttons to return to Late/Early operation. Try it.

Straight Odometer/Speedometer

ProComp can also be used as a straight odo. Simply **dELete** any Race Data from memory & go to Ready. It then runs with the 3 readouts described below.

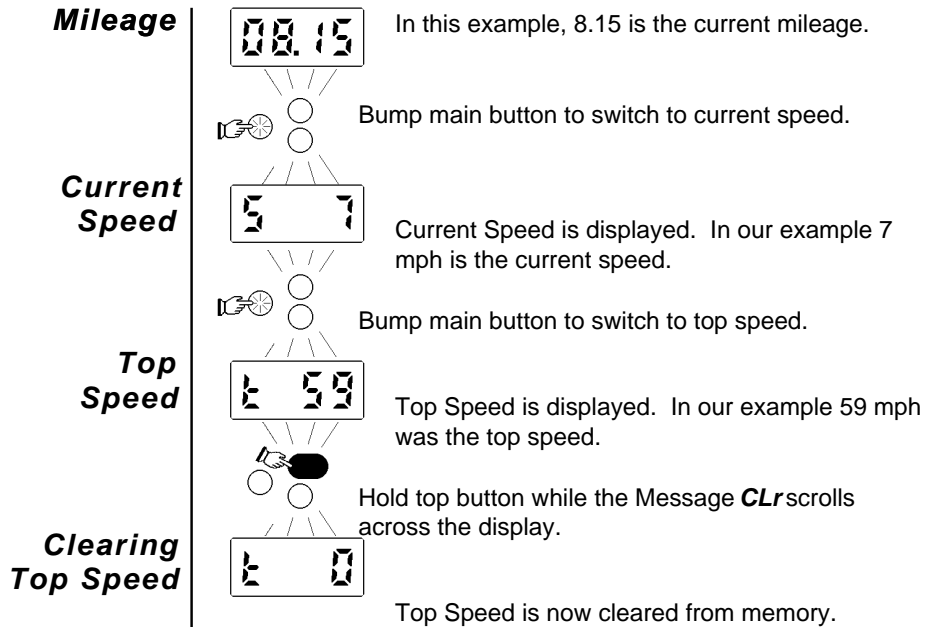

When used as a straight odo with no Program in memory, **AutoCal** is always OFF regardless of your setting in **CAL**. This is useful for play riding or laying out a course.

Count

Proper set up of your magnet & sensor is very important for reliable performance. Two things are very critical for accurate tracking of Mileage:

1. You must get 1, and ONLY 1, closure of the sensor for each wheel revolution. It's possible to position the magnet & sensor to get 2 or even 3 closures per revolution.
2. The sensor should stay closed for the greatest number of degrees of wheel movement possible. Rotate the wheel VERY slowly while checking.

In other words, a good, solid SINGLE closure.

The Count readout has 2 useful functions for testing your setup:

- It will count the number of times your sensor has closed.
- A tick comes on while the sensor is being held in a closed position.

How to get to Count

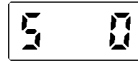

Go to the current speed readout.



Hold top button while the Message **cnt** scrolls across the display.



The Count readout. If you wanted to get out of Count you would bump the Main button.

Using a needle nose pliers or a short piece of wire, short across the 2 connectors on the wire pair coming from your instrument head.

sensor closed

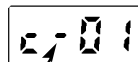

Note how the value increments each time you short the wires, plus how the tick stays on for the entire time you keep the wires shorted.



After you install your magnet & sensor BE SURE to check for a good, solid SINGLE closure.

Calibrate wheel size

You can set ProComp to the circumference of your particular front tire. We call this setting the Programmed Wheel Size, and your setting will be retained until you either change it or replace the batteries. Also from **CAL**, you can switch to Metric operation, for distance in Kilometers & speed in KPH.

Wheel size

Tire circumference is best measured by placing 2 matching reference marks, one on your tire and another on a suitable flat surface such as a concrete slab. Roll the bike one wheel revolution WITHOUT the rider aboard, make a second mark on the floor, then measure the distance between the marks.

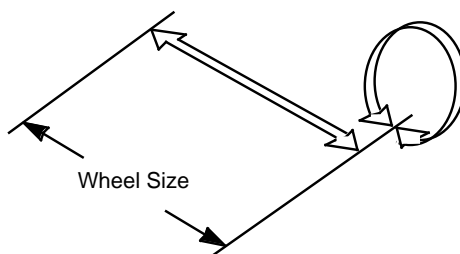

How to set



Move to the Main Menu and select **C**



..... then move to **CAL**



The Programmed Wheel Size is in *inches*.

Programmed Wheel Size

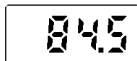

84.5 inches of circumference. If you wish to edit this value, bump top button.

84.5 inches is automatically loaded as the Programmed Wheel Size each time you replace the batteries.

(Continued on next page)

Calibrate wheel size

Changing the wheel size 1.0 INCH will affect the Mileage Readout approximately a .10 of a mile per 10.0 miles. If you want your instrument to run "faster", enter a LARGER wheel size. To "slow" it down, enter a SMALLER wheel size.

Switching between English & Metric



Stop at the *inch* Message. Long holding the top allows you to switch back & forth.

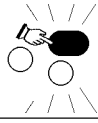

Long hold the top button. The Message **CEt** will scroll across the display.



Your Programmed Wheel Size is now in centimeters. Your distance will be Kilometers & speed KPH.



Bump bottom to move to next step.

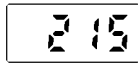

215 centimeters. If you wish, bump top now to adjust to another circumference.

- You may switch back & forth as much as needed.
- NOTE: Your Trip & Odo Distance will accumulate in either Miles or kilometers, depending on the **CAL** setting during each use. Therefore, your Odo Distance will represent a mixture of Miles & kilometers if you switch between each use.

Odo Distance can be edited, allowing you to manually perform the conversion.

Installing Batteries



A new chip has recently become available which ensures clean power up. Shorting is no longer necessary, but not harmful to the instrument.

Loosen screws approx. 5 turns to allow battery installation.

negative side

Stepped side of all 3 batteries MUST face down.

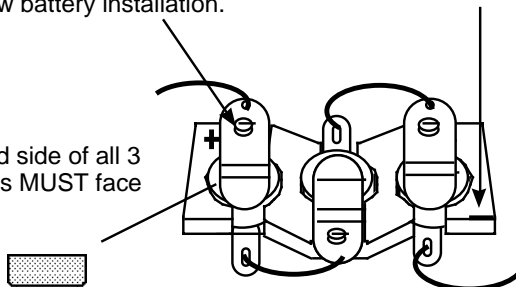

**#357
Silver Oxide**

- Use **357 SILVER OXIDE** Watch/Calculator batteries.
- Coat the ends of the batteries lightly with Vaseline.
- Silver Oxides should provide approx. 100 hours of **ON** time.
- It is best to replace the batteries every 10 to 15 events.

***your
settings
may change***

Each time the batteries are replaced, the following items are set to:

- *Program - Empty (erased)*
- *AutoCal - ON*
- *CAL - Inch & 84.5*
- *Ahead - 1 minute*
- *Top Speed, Trip & Odo Distance - 0*



DO NOT use LOCTITE®, Silicone Seal, or Contact Cleaner on any part of the instrument.

More Info

Multiple loops with Resets to 000.0



Mileage at end of loop not known?

Odo Distance

complicated Race sheets

Many Races use several loops, with each loop starting at mile **000.0** ProComp can handle these with ease. For the end of each loop just enter a **Reset** from the Mileage at the end of the loop to **000.0** In some cases this Reset may be followed by both Free time or a Speed change at **000.0** You can enter the Free time 1st or the Speed 1st, the order does not matter. Also, if the Speed at the start of the new loop is the same as the last section of the previous loop it is not necessary to enter a Speed at **000.0**

DO NOT enter both a Reset to **000.0** AND a **LEAP** to **000.0** back-to-back. Your instrument will treat these as 2 separate loops. Use **ONLY** a Reset to **000.0**

In some cases, the Mileage to the end of a loop may not be posted by the club. You will have to calculate this Mileage.

- Determine the number of minutes for the last section of the loop.
- Calculate the distance traveled for each minute at the speed average of that section. For this, divide the speed by 60.
- Multiply the minutes by the distance traveled each minute.
- Add this to the Mileage at the START of the last section.

EXAMPLE: The last section STARTS at 41.3 and runs at 24 mph for 31 minutes.

- 31 minutes long
- .4 miles per minute ($24 \div 60 = .4$)
- 12.4 miles long ($31 \text{ minutes} \times .4 = 12.4$)
- 53.7 is the END of the last section ($41.3 + 12.4 = 53.7$)

Your Odo Distance in **InFo** can be edited, allowing you to update your distance after changing the batteries. Just write down the distance, change the batteries, then change the distance from **0000** to the desired number.

Long Race sheets are a pain. Try using different colored Hi-Liters to mark each type of entry in a unique color prior to starting to Program.

Cautions



ALWAYS short across your batteries after installing them!
See ***Battery Installation*** page for instructions.



DO NOT use LOCTITE®, Silicone Seal, or Contact Cleaner on any part of your instrument head

Ignition Interference

The high energy ignition systems on today's motorcycles emit noise which, in rare cases, may interfere with the operation of your instrument. (Static heard on radios is an example of such noise). Although many safeguards have been built into your instrument to shield out this interference, take the following steps to minimize the possibility of any such problems:

- Keep throttle cable, clutch cable, and kill switch wire as far away from the instrument as possible.
- Take special care not to route these cables above the display window of the instrument.
- Remove the gas tank and make sure that throttle and clutch cables are not routed directly against the spark plug wire or ignition coil.

Sensor Troubleshooting

If your Mileage accumulates too slowly, too rapidly, or fails to register at all, perform the checks below.

First read the Count page in this manual, then switch to the Count readout for all Tests.

Magnet slot check

- Rotate wheel very SLOWLY.

Readout Counts more than once each revolution?

- **Loosen magnet screw & rotate magnet slot until a SINGLE hit is achieved. A long, solid, single hit is the goal.**

Head Wire check

- Disconnect both sensor wires from head wires.
- Short head wire connectors together using a short piece of wire.

Setup checks

Readout Counts?..... If yes O.K., go to next check

- Magnet-to-sensor gap 3/32" to 3/16" (2.5mm to 5mm)
- Magnet passes over sensor body

Connector check

Everything OK.? **Go to next check**

- Reconnect head wires to sensor wires.
- Stop wheel with magnet directly over sensor.
- Rap connectors sharply with your finger nail.

Broken wire check

Readout counts?..... **Poor connection**

- Shake sensor wires along their entire length with the magnet still over sensor.

Readout counts?..... **Broken wires**

Instrument Troubleshooting

If your readout goes blank while riding, or the instrument does not respond to pressing the buttons, perform the checks below.

Reset Instrument

- Short across the batteries for approx. 2 seconds.
(Refer to ***Battery Installation*** page of manual)

Readout still blank?..... **Go to next check**

Voltage check

- Position test leads at the same points on the battery holder used to reset instrument

Voltage below 4.1?.....

- **Replace batteries with fresh SILVER OXIDE**
- **Be sure to short across batteries**

Operation check

- Increment and decrement the Mileage readout, then move to ***ChEc.***

Everything O.K.?..... **Instrument Head O.K.**

Be aware that problems which occur ONLY while your engine is running are probably caused by interference from the bike's ignition system. Be sure to read the "***Cautions***" page of this manual.

Limited Warranty

ICO CORPORATION warrants to the original owner that this ICO ProComp is free of defects in materials or workmanship in the Instrument head or remote thumb switch for a period of 1 year from the date of purchase. The sensor assembly is warranted for a period of 6 months from the date of purchase. This warranty does not cover damage resulting from improper installation, accident, misuse, or abuse.

In case of difficulties

Many problems can be resolved **WITHOUT** returning the instrument to us. Please follow these steps to assure the fastest possible solution to your difficulties

- 1st refer to the ***Trouble Shooting*** section of this manual
- If the problem cannot be identified using the manual, Technical Assistance is provided at the following number:



Technical Assistance (504) 882-3107

Send UPS 2nd DAY AIR (Blue Label)

Repair Info

Please include:

- **DATE** you need your instrument back
- **DESCRIPTION** of the problems you encountered
- **RETURN** address (P.O. Boxes are not acceptable)
- **PHONE** number (Day Time)
- **PROOF** of purchase if no warranty card was sent in
- **CREDIT CARD NUMBER** for payment

Post Office Address

UPS Address

ICO Racing

PO Box 1050

or

29370 Dinkins Drive

Bayou Lacombe, Louisiana 70445

ChEc Map, with no Race Program

ChEc is where you go to enter a Race Program, set your wheel size **CAL**ibration, or check **InFo**. NOTE: You can go into **ChEc** ONLY while the readout is at **00.00**.

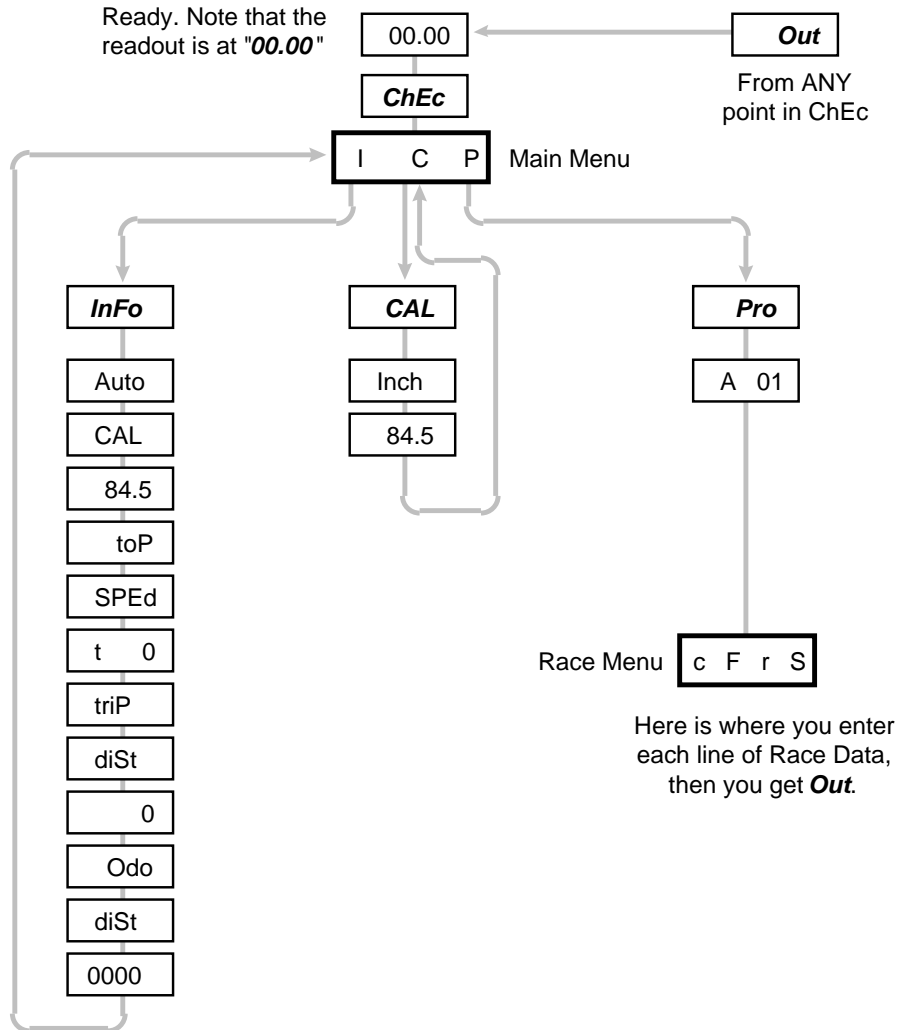

ChEc Map, with a Race Program

If you have a Program in memory, your Ahead setting is displayed at Ready. Don't forget, you can go into **ChEc** ONLY while at Ready. Once ProComp is running in a Race you CANNOT go into **ChEc**.

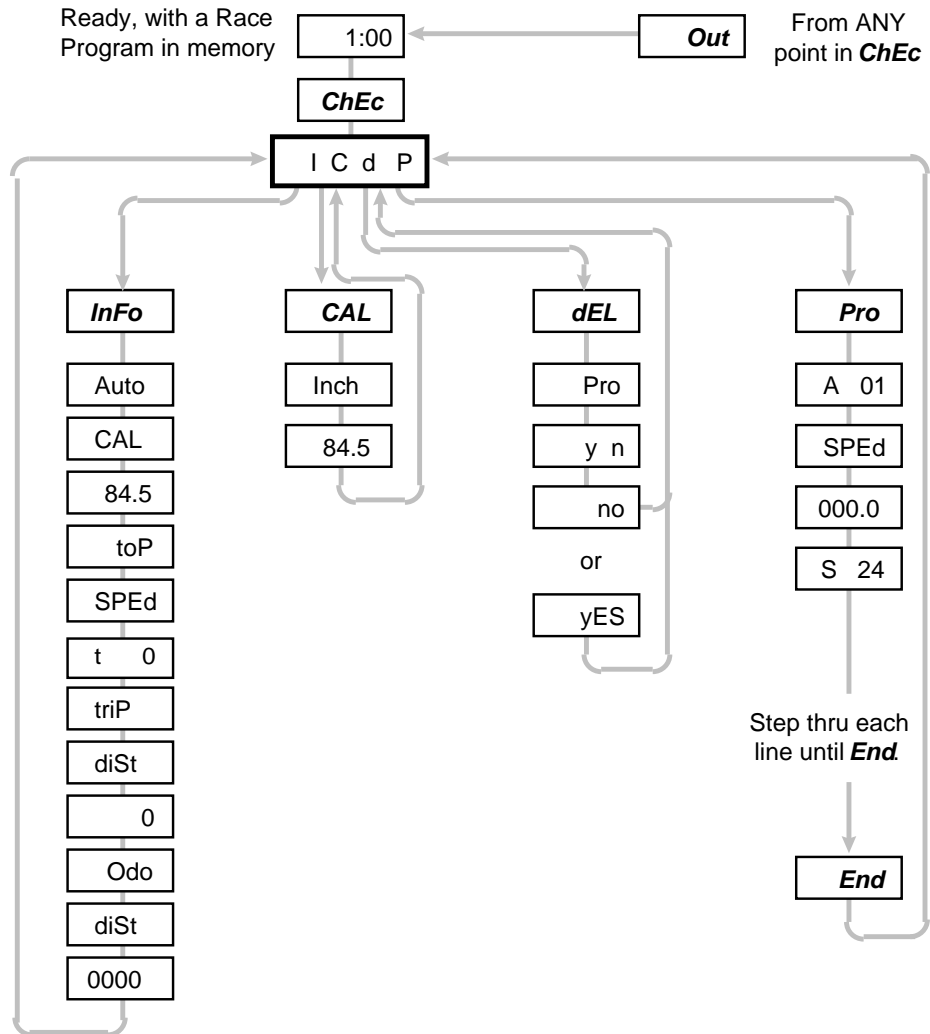

Quick Shots

ChEc

To	Start here:	Do this:
Turn On	OFF 	
move into ChEc	Ready 	
move to CAL	Main Menu 	
move to InFo	Main Menu 	
change any value	any number 	
switch between Inch & centimeter	Inch/CETi Message 	
Back Step	at ANY steady readout 	
Automatic Scan	at any point Hold for 2 readouts 	

To	Start here:	Do this:
begin Programming	Main Menu 	
enter a Speed	Race Menu 	
enter a Reset	Race Menu 	
enter Free time	Race Menu 	
enter a Known control	Race Menu 	
line where you wish to add add a single line		
line you wish to delete delete any single line		
delete an entire Program	Main Menu 	
Out of ChEc	at ANY point at ANY readout 	



- The 1st entry MUST be a Speed which starts at **000.0**
- A Speed of **00** is not acceptable.
- All lines MUST be entered in the order in which they occur.
- Each Mileage must be equal to, or greater than, the previous entry (Except Resets to **000.0**)
- DO NOT use a **LEAP** for a Reset to **000.0** (Multiple loops which start at **000.0**)

