

Rallye 2

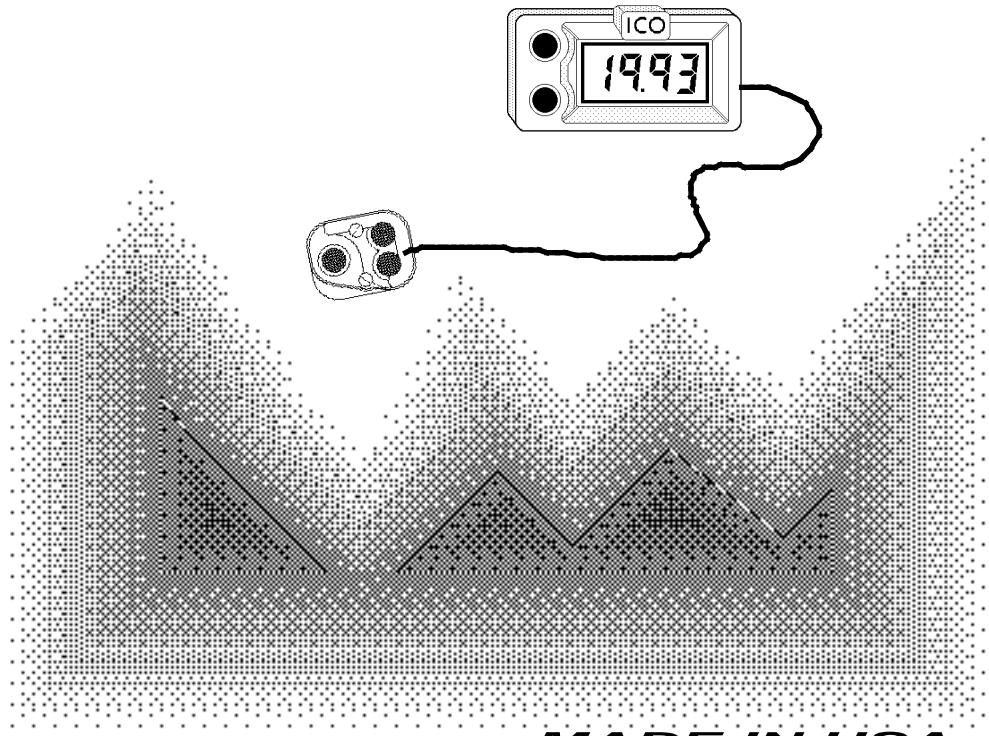

MADE IN USA

Install Batteries



A new chip has recently been installed in the Rallye 2 to ensure clean power up. Shorting is no longer necessary, but not harmful to the instrument.

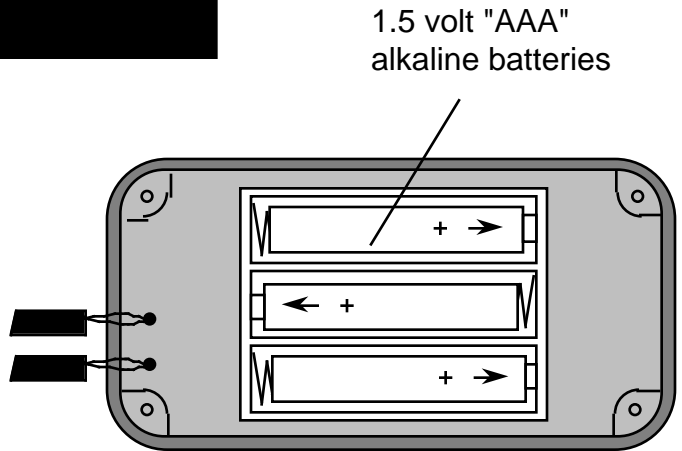

After installing the batteries be sure to attach the "Foam Tape" as shown in the back of this manual.

- AAA battery life is approx 400 hours of "ON" time.
- Replace ALL 3 batteries when the digits of the display become too light to read

Shut Down

Running

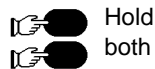

After installing the batteries, your instrument will run as a clock. Hold both buttons on the instrument to **SHUT DOWN**, then bump the bottom button to turn it back on.

Off

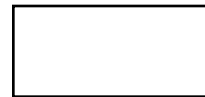

Distance

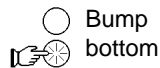

- After each day's use, **SHUT DOWN** to prolong battery life

Connecting the Thumb Switch

Next we will connect the Thumb Switch. Connect one of the red wires of the switch to one of the red wires coming out of the instrument. Then connect the remaining wires red-to-red and black-to-black. Next bump the top button of the Thumb Switch two times, followed by two bumps of the bottom switch. If the top adjusts the readout to "00.2" and the bottom adjusts back to "00.0", the red wires are connected properly. If not, the red wires are reversed and should be reconnected.

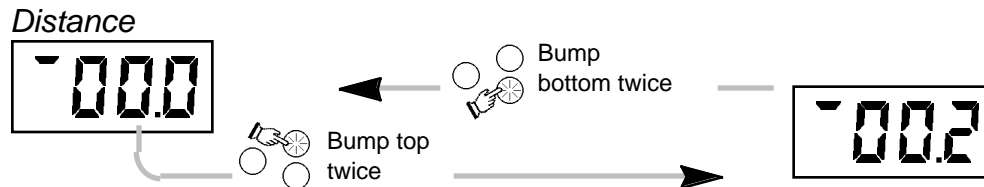

Once the Thumb Switch has been connected you can access all features without moving your hand off of the handlebars. The only exception is that you must use the bottom button on the instrument head to turn the instrument on. The bottom or top button on the Thumb Switch works exactly as the corresponding button on the instrument, while pressing the middle button on the Thumb Switch is equivalent to pressing both buttons on the instrument head.

Thumb Switch buttons

Instrument head buttons

| | | | | |
|-------------------------------|--|---|--|--|
| Bumping the bottom button ... | | = | | ... bumping the bottom button on the instrument. |
| Bumping the top button ... | | = | | ... bumping the top button on the instrument. |
| Holding the bottom button ... | | = | | ... holding the bottom button on the instrument. |
| Holding the top button ... | | = | | ... holding the top button on the instrument. |
| Bumping the middle button ... | | = | | ... bumping both buttons on the instrument. |
| Holding the middle button ... | | = | | ... holding both buttons on the instrument. |

Functions

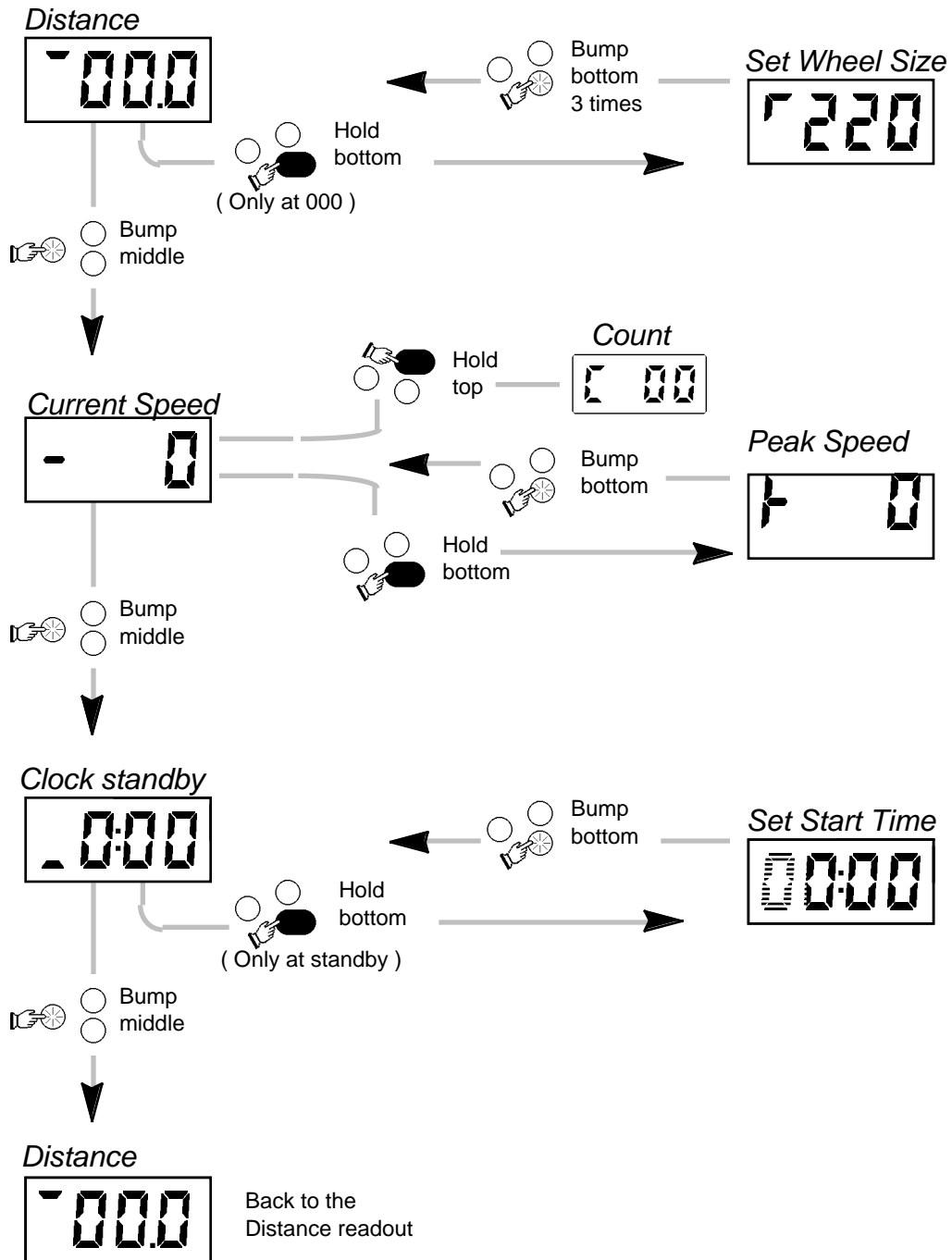

Distance

Adjusting the readout

+ Distance

27.8



Hold top



Bump top

→ +.1



Bump bottom

→ -.1



Hold bottom



Moving the decimal

+ Distance

27.8



27.82

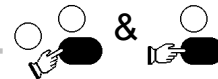

+ Distance

27.8

Hold BOTH bottom buttons at the same time until the decimal stops flashing.

Repeat to move decimal back.

Zeroing the Distance

+ Distance

27.8

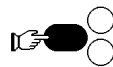

Hold middle

Zero Distance

- Reads kilometers (km) up to 999.9 or 99.99, then starts over at 000.0 or 00.00
- If you wish to track distance in MILES instead of kilometers, use a wheel size of (cm x .62).

Set Wheel Size

The wheel size used by the instrument to calculate distance can be adjusted to match your front tire circumference. Place a mark on your tire and a corresponding mark on the floor. Roll the wheel one revolution, then place a second mark on the floor. This is your actual wheel size. For our example we will adjust the instrument to a wheel size of 215 cm.

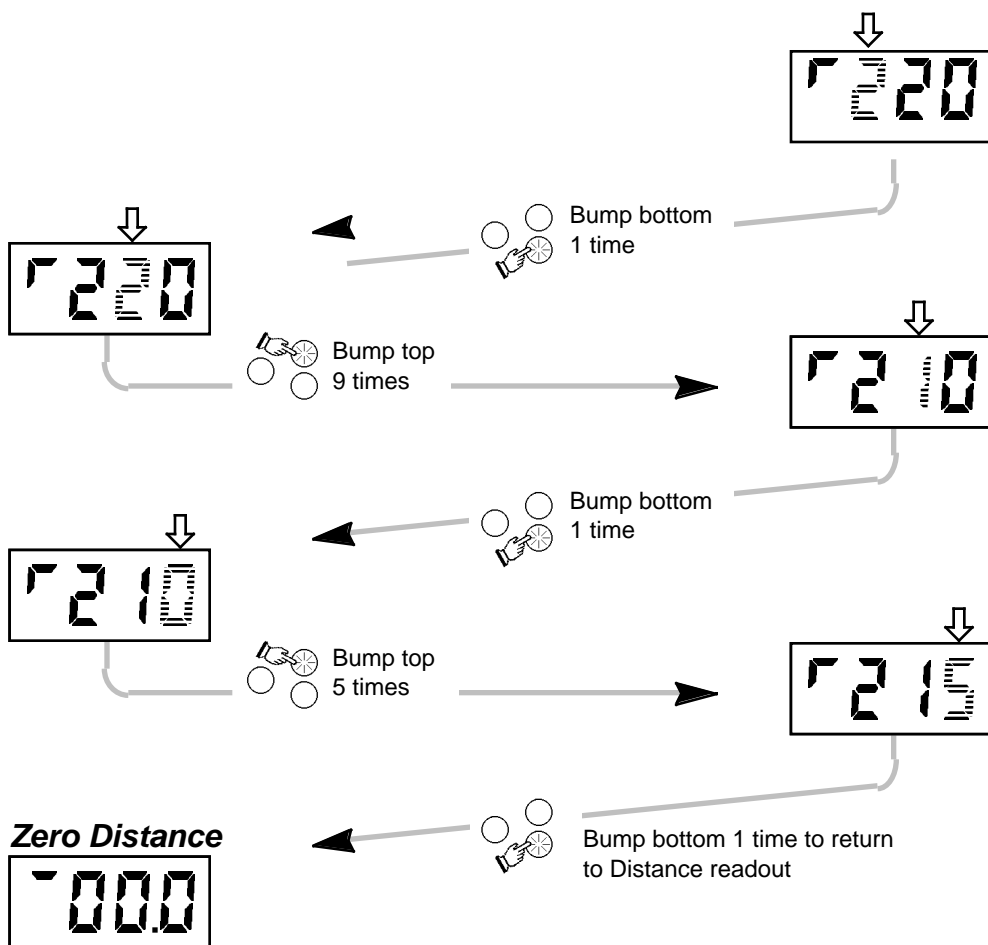
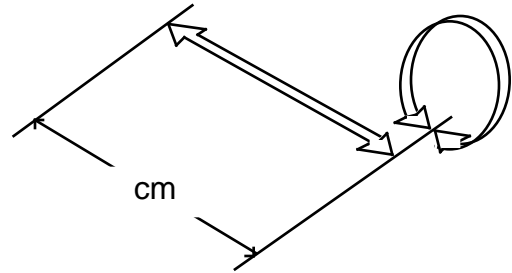

Count

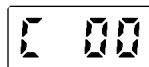
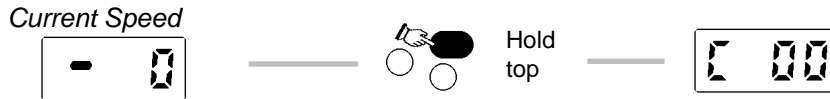

The Count readout has 2 useful functions for testing your setup:



- It will count the number of times your sensor has closed.
- A tick comes on while the sensor is being held in a closed position.

SENSOR WARNING



Multiple counts will cause the instrument to read 2 or 3 times actual distance.

Please double check your sensor installation by the following steps :

SENSOR CHECK AFTER INSTALLATION

Be sure that each revolution of the wheel closes the sensor only once, NOT 2 or 3 times. Use the Count (cnt) feature of the instrument for testing. (Hold top button while in current speed).

- Very slowly rotate the front wheel while the magnet passes over the sensor. Check that the sensor counts (closes) **ONLY ONCE** for each pass.
- If it does not count, or it counts 2 or 3 times per pass, loosen the magnet screw and rotate the magnet until a single count is achieved each pass. The sensor should stay closed for the greatest number of degrees of wheel movement possible.

In other words, a good, long SINGLE closure.

SENSOR CHECK WHILE RIDING

You can check your sensor during riding, by viewing your TOP SPEED (hold the main button while in current speed). If you have an extremely high top speed, your not getting one single closure. Multiple counts will cause the distance to multiply.

Peak Speed

You can view the Peak Speed reached during a run. Also, you can reset the Peak Speed readout to zero.

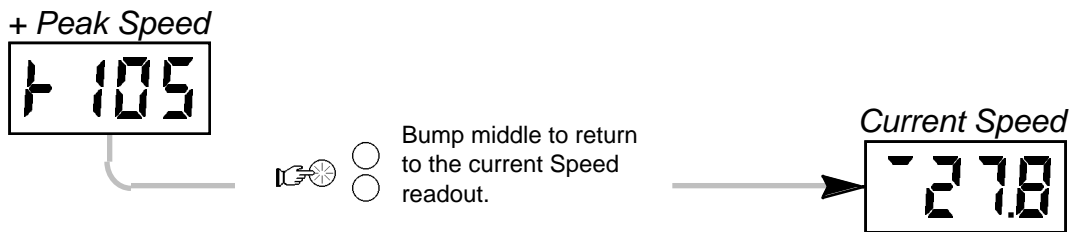

Zeroing Peak Speed

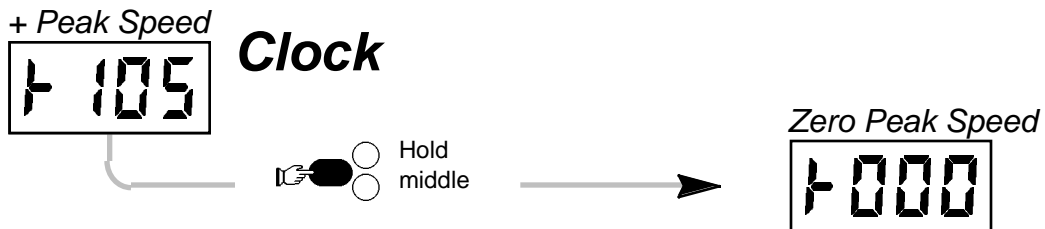

NOTE: The Peak Speed reading remains in memory until it is reset to zero. Be sure to reset it before each ride if you wish to measure the correct Peak Speed for that ride.

Clock

Starting the Clock

From the Clock Standby (Colon not flashing) the Clock is started by bumping the bottom button. See the next page for instructions on how to set a Starting Time other than 00:00

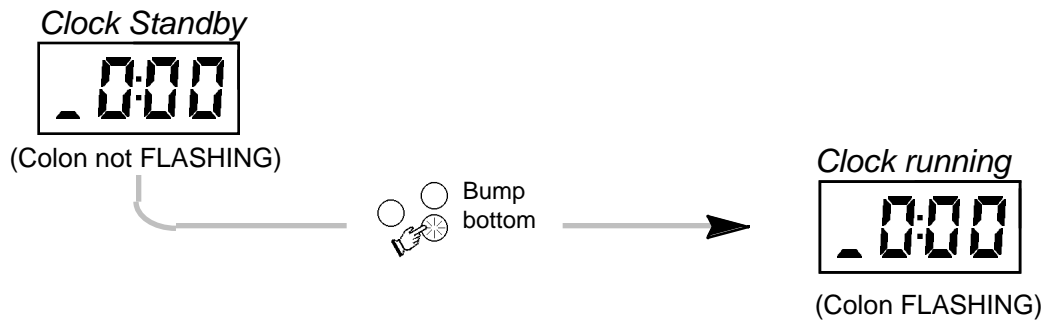

Stopping the Clock

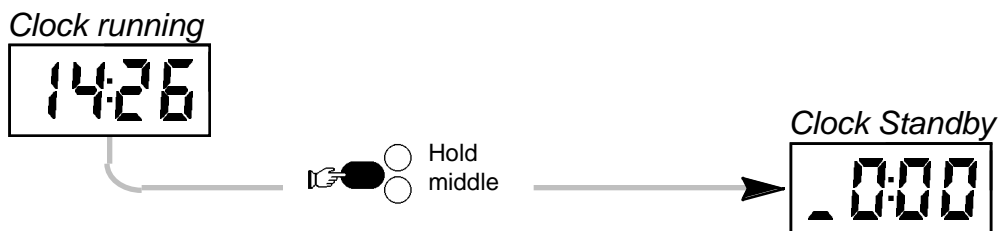

- The Clock runs to 23:59, then starts over at 00:00
- Left two digits are hours, right two digits are minutes

Set Start Time

Our example:
08:15

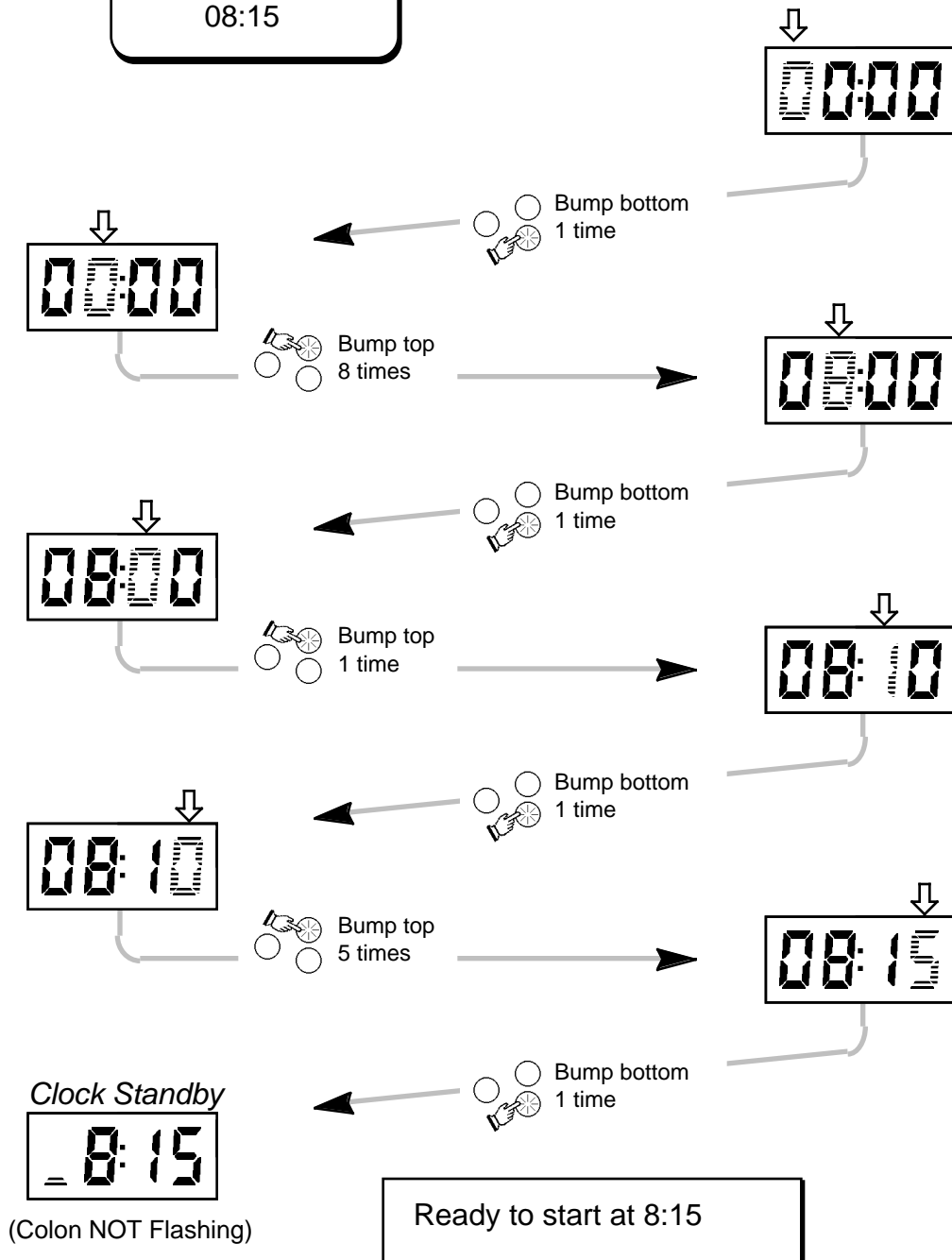

Shut Down after a run

- After each day's use, Shut Down to prolong battery life.
- To Shut Down you must first Zero the Distance readout, then release the middle button. Next hold the middle button once again to Shut Down.

Zero the Distance readout ...

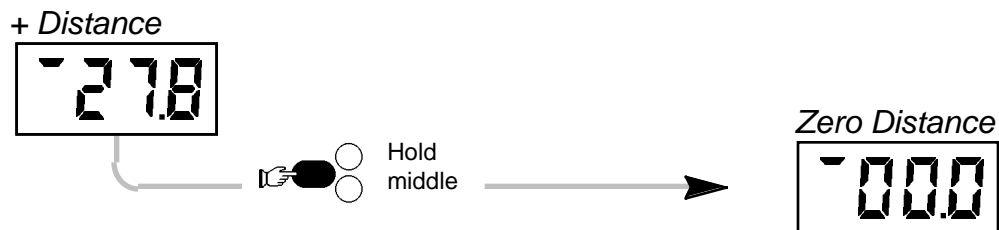

... then Shut Down

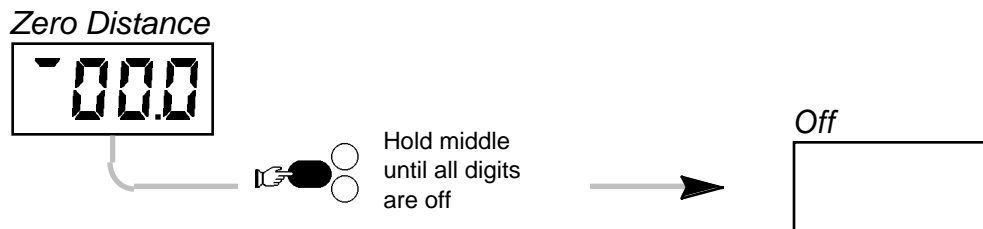

Foam Installation

onto the case bottom

After installing the case studs into the instrument bottom, install "Foam" in the location shown. Install the side with the shiny slick tape towards the batteries.

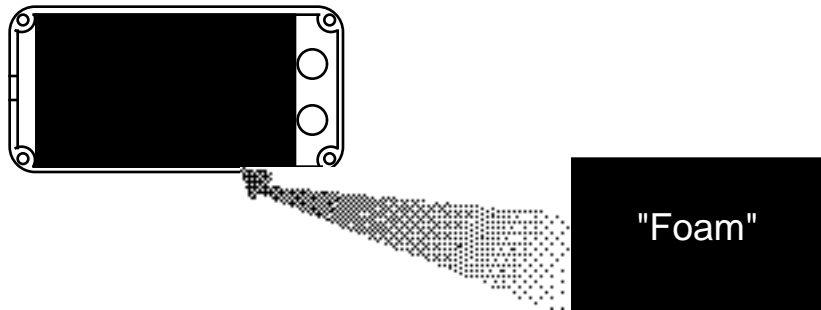

Using any other type of tape may result in instrument malfunction during a race.

Instrument Troubleshooting

If your readout goes blank while riding, or the instrument does not respond to the buttons, perform the checks below.

Voltage check

- Position test leads at the same points on the battery holder used to short the batteries.

Voltage below 3.8.?.....

- **Replace batteries with fresh ALKALINE batteries, then short across them**

Operation check

- Increment and decrement the Distance readout, switch to current Speed, then Clock.

Everything O.K.?..... Instrument Head O.K.

If your instrument quits while riding, the problem may be due to interference from the ignition system. Check the following causes and correct as needed:

1. Throttle cable routed too close to instrument
2. Throttle cable routed too close to coil or spark plug wire
3. Plug wire rubbing frame
4. Instrument case or bottom may have a crack in it

Sensor Troubleshooting

If your Distance accumulates too slowly, too rapidly, or fails to register at all, perform the checks below. Keep in mind that a break in the wiring does not ALWAYS cause the instrument to quit registering Distance altogether. The broken wire may be making intermittent contact, resulting in a PARTIAL accumulation of Distance.

Head Wire check

- Switch to Current Speed
- Disconnect both sensor wires from head wires
- Short head wire connectors together using a short piece of wire

Readout shows Speed?..... **Go to next check**

Setup checks

- Magnet-to-sensor gap 2.5mm to 5mm
- Magnet slot 45 degrees to sensor body
- Magnet passes over sensor body

Everything OK.? **Go to next check**

Connector check

- Reconnect head wires to sensor wires
- Stop wheel with magnet directly over sensor
- Rap connectors sharply with your finger nail

Readout shows Speed?..... **Poor connection**

Broken wire check

- Shake sensor wires along their entire length with the magnet still over sensor

Readout shows Speed? **Broken wires**

Pickup check

- Spin wheel

Readout shows steady Speed?

- **Rotate magnet slot**

Button summary

Primary Functions

| To: | Start here: | Do this: |
|-----------------------|-------------------|----------|
| Turn On | OFF | |
| move to Current Speed | Distance | |
| move to Clock | Current Speed | |
| move to Distance | Clock | |
| zero Distance | + Distance | |
| Shut OFF | Zero Distance | |
| move the decimal | Distance | and |

Setup

| To: | Start here: | Do this: |
|--------------------|-------------------|----------|
| Set Wheel Size | Zero Distance | |
| move to Peak Speed | Current Speed | |
| Zero Peak Speed | Peak Speed | |
| Set Start Time | Clock standby | |
| Start the Clock | Clock standby | |
| Stop the Clock | running Clock | |



- Be sure to install the foam tape.
- Shut OFF after each use.